

V-Series

Horizontal Outdoor

Sizes: V1 – V5

Legend:

Down Dis: Down (Vertical) Discharge
End Dis: End (Horizontal) Discharge
Base Cab: The burner and blower section
IH: Inlet Hood with bird screen
FIH: Filtered Inlet Hood
SAFS: Side Access Filter Section
DC: Duct curb and legs
Curb: Full roof curb

PRELIMINARY DRAWING

PROPRIETARY

V1 NOTES ONLY

- 1 (1) ACCESS DOOR PER SIDE IN LIEU OF (2) PER SIDE AS SHOWN
- GAS & ELEC. BOX EXTENDS FULL CABINET LENGTH
- 2 F DIMENSION ON OPPOSITE CONTROL SIDE = 5"

GENERAL NOTES

UNLESS OTHERWISE NOTED, ALL EXTERIOR SURFACES ARE TO BE GALVANIZED STEEL.

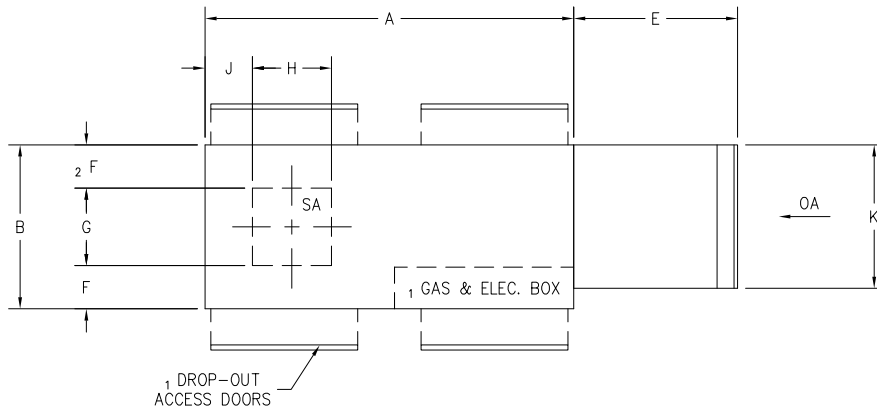

PLAN VIEW

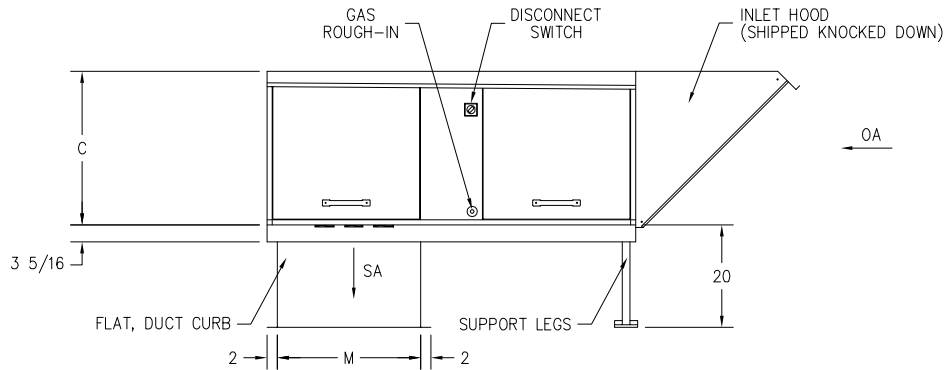

CONTROL SIDE VIEW

	V1	V2	V3	V4	V5
A	50	72	92	96	96
B	28	32	40	48	55
C	24	30	33	38	48
E	27	32	41	37-1/2	47
F	10-1/2 ²	7-3/16	9-11/16	12-1/16	14-1/8
G	12-1/2	17-5/8	20-5/8	23-7/8	26-3/4
H	13-3/8	15-7/16	17-7/8	20-7/8	26-3/4
J	8	9-1/4	10-1/2	12-1/4	13-1/2
K	22-7/8	27-7/8	34-7/8	42-7/8	52-7/8
M	24	28	36	44	51
UNIT WEIGHT	325 LBS	445 LBS	635 LBS	805 LBS	1,060 LBS
CURB WEIGHT	40 LBS	45 LBS	55 LBS	60 LBS	70 LBS



* 5496 N. RIVERVIEW DR. * KALAMAZOO, MI 49004 *

PROJECT NAME:

V-SERIES DIM. CHART

REF. NO./JOB NO.:

V1-V5

MODEL:

V1-V5

TAG:

-

DRAWN BY:

E. CLARK

DATE:

09-28-16

SCALE:

NONE

CERTIFIED BY:

DRAWING NO.:

S:\UNIT DRAWINGS\V1-V5

PRELIMINARY DRAWING

PROPRIETARY

V1 NOTES ONLY

- 1 (1) ACCESS DOOR PER SIDE IN LIEU OF (2) PER SIDE AS SHOWN
- GAS & ELEC. BOX EXTENDS FULL CABINET LENGTH
- 2 F DIMENSION ON OPPOSITE CONTROL SIDE = 5"

GENERAL NOTES

UNLESS OTHERWISE NOTED, ALL EXTERIOR SURFACES ARE TO BE GALVANIZED STEEL.

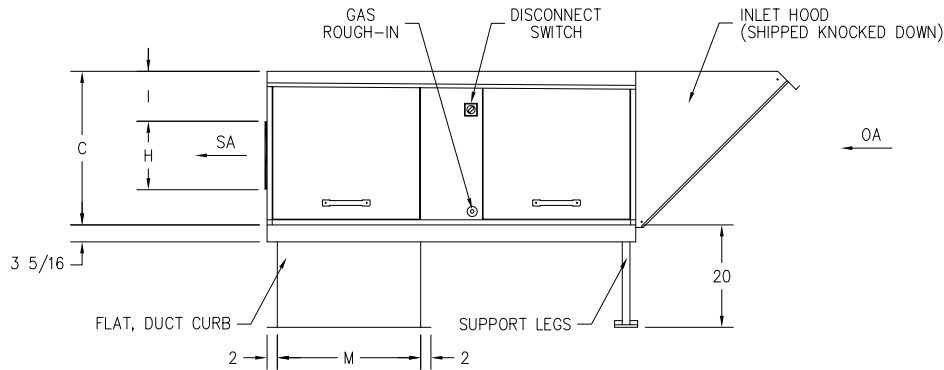
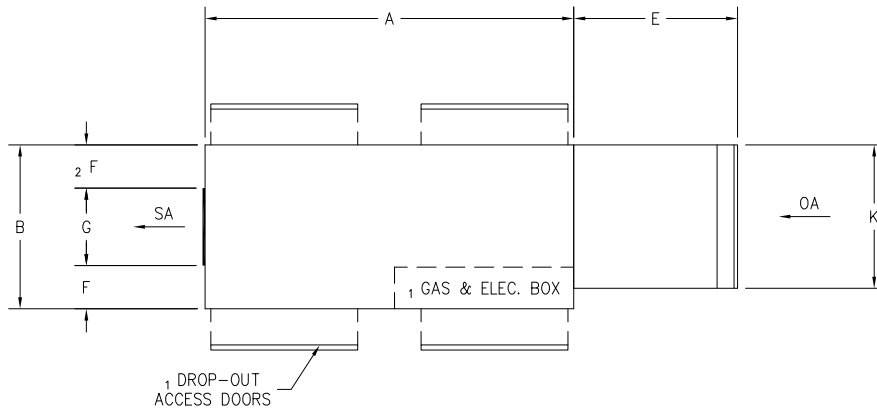

	V1	V2	V3	V4	V5
A	50	72	92	96	96
B	28	32	40	48	55
C	24	30	33	38	48
E	27	32	41	37-1/2	47
F	10-1/2 ²	7-3/16	9-11/16	12-1/16	14-1/8
G	12-1/2	17-5/8	20-5/8	23-7/8	26-3/4
H	13-3/8	15-7/16	17-7/8	20-7/8	26-3/4
I	3-3/4	6-5/16	5-3/4	6-1/8	8-5/16
K	22-7/8	27-7/8	34-7/8	42-7/8	52-7/8
M	24	28	36	44	51
UNIT WEIGHT	325 LBS	445 LBS	635 LBS	805 LBS	1,060 LBS
CURB WEIGHT	40 LBS	45 LBS	55 LBS	60 LBS	70 LBS



* 5496 N. RIVERVIEW DR. * KALAMAZOO, MI 49004 *

PROJECT NAME:

V-SERIES DIM. CHART

REF. NO./JOB NO.: V1-V5

MODEL: V1-V5

TAG: -

DRAWN BY: E. CLARK

DATE: 09-28-16

SCALE: NONE

CERTIFIED BY:

DRAWING NO.: S:\UNIT DRAWINGS\V1-V5

PRELIMINARY DRAWING

PROPRIETARY

V1 NOTES ONLY

- 1 (1) ACCESS DOOR PER SIDE IN LIEU OF (2) PER SIDE AS SHOWN
- GAS & ELEC. BOX EXTENDS FULL CABINET LENGTH
- 2 F DIMENSION ON OPPOSITE CONTROL SIDE = 5"

GENERAL NOTES

UNLESS OTHERWISE NOTED, ALL EXTERIOR SURFACES ARE TO BE GALVANIZED STEEL.

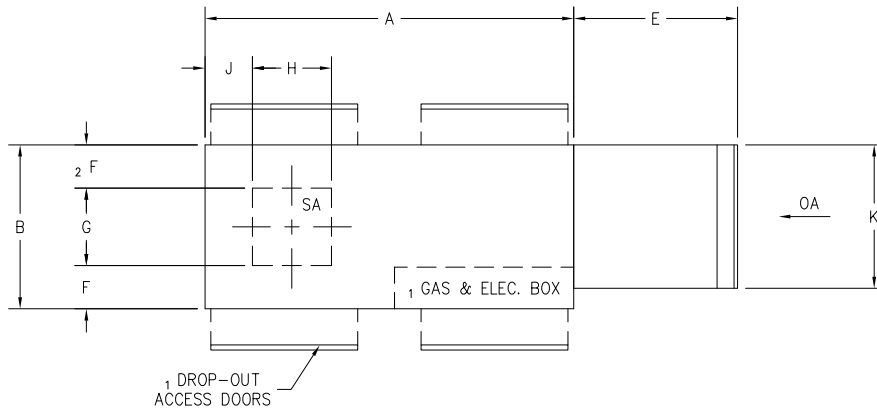

PLAN VIEW

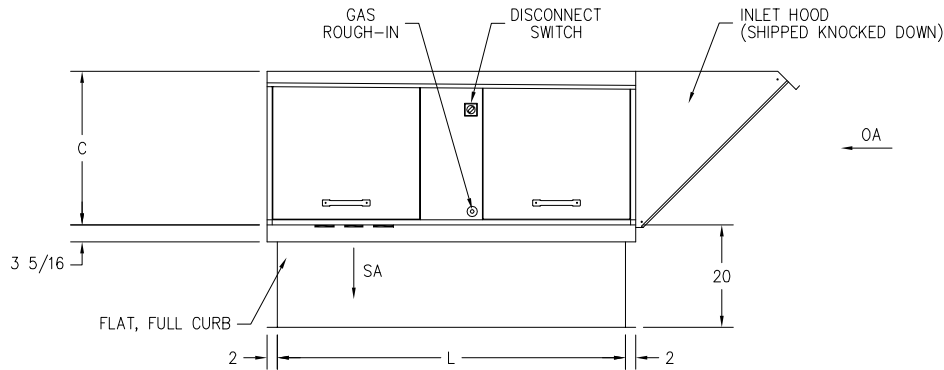

CONTROL SIDE VIEW

	V1	V2	V3	V4	V5
A	50	72	92	96	96
B	28	32	40	48	55
C	24	30	33	38	48
E	27	32	41	37-1/2	47
F	10-1/2 ²	7-3/16	9-11/16	12-1/16	14-1/8
G	12-1/2	17-5/8	20-5/8	23-7/8	26-3/4
H	13-3/8	15-7/16	17-7/8	20-7/8	26-3/4
J	8	9-1/4	10-1/2	12-1/4	13-1/2
K	22-7/8	27-7/8	34-7/8	42-7/8	52-7/8
L	46	68	88	92	92
UNIT WEIGHT	325 LBS	445 LBS	635 LBS	805 LBS	1,060 LBS
CURB WEIGHT	45 LBS	55 LBS	80 LBS	90 LBS	95 LBS



* 5496 N. RIVERVIEW DR. * KALAMAZOO, MI 49004 *

PROJECT NAME:

V-SERIES DIM. CHART

REF. NO./JOB NO.:

V1-V5

MODEL:

V1-V5

TAG:

-

DRAWN BY:

E. CLARK

DATE:

09-28-16

SCALE:

NONE

CERTIFIED BY:

DRAWING NO.:

S:\UNIT DRAWINGS\V1-V5

PRELIMINARY DRAWING

PROPRIETARY

V1 NOTES ONLY

- 1 (1) ACCESS DOOR PER SIDE IN LIEU OF (2) PER SIDE AS SHOWN
- GAS & ELEC. BOX EXTENDS FULL CABINET LENGTH
- 2 F DIMENSION ON OPPOSITE CONTROL SIDE = 5"

GENERAL NOTES

UNLESS OTHERWISE NOTED, ALL EXTERIOR SURFACES ARE TO BE GALVANIZED STEEL.

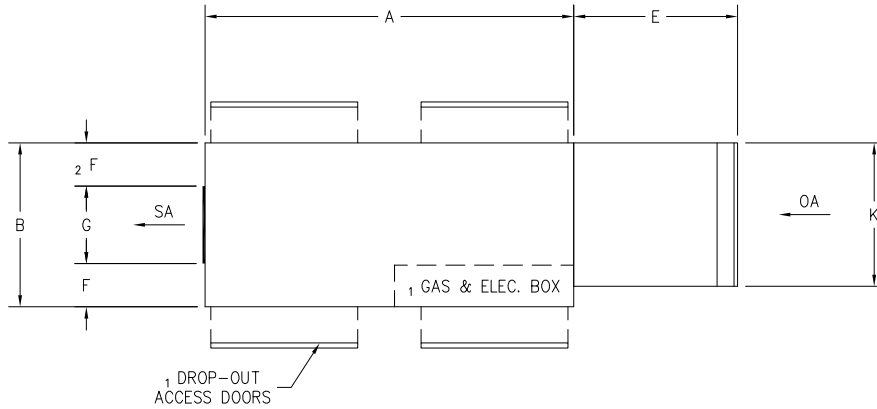

PLAN VIEW

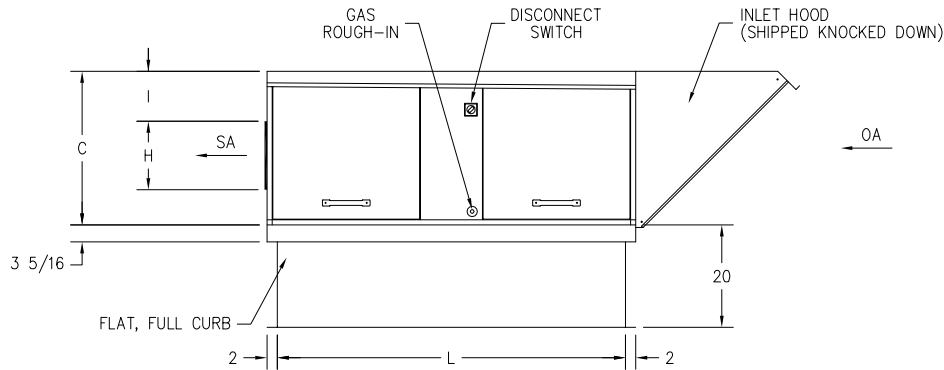

CONTROL SIDE VIEW

	V1	V2	V3	V4	V5
A	50	72	92	96	96
B	28	32	40	48	55
C	24	30	33	38	48
E	27	32	41	37-1/2	47
F	10-1/2 ²	7-3/16	9-11/16	12-1/16	14-1/8
G	12-1/2	17-5/8	20-5/8	23-7/8	26-3/4
H	13-3/8	15-7/16	17-7/8	20-7/8	26-3/4
I	3-3/4	6-5/16	5-3/4	6-1/8	8-5/16
K	22-7/8	27-7/8	34-7/8	42-7/8	52-7/8
L	46	68	88	92	92
UNIT WEIGHT	325 LBS	445 LBS	635 LBS	805 LBS	1,060 LBS
CURB WEIGHT	45 LBS	55 LBS	80 LBS	90 LBS	95 LBS



* 5496 N. RIVERVIEW DR. * KALAMAZOO, MI 49004 *

PROJECT NAME:

V-SERIES DIM. CHART

REF. NO./JOB NO.: V1-V5

MODEL: V1-V5

TAG: -

DRAWN BY: E. CLARK

DATE: 09-28-16

SCALE: NONE

CERTIFIED BY:

DRAWING NO.: S:\UNIT DRAWINGS\V1-V5

PRELIMINARY DRAWING

PROPRIETARY

V1 NOTES ONLY

GENERAL NOTES

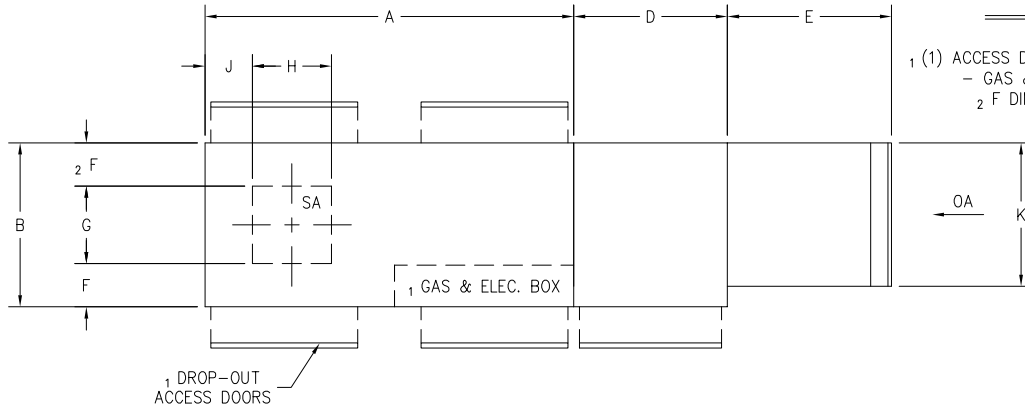

PLAN VIEW

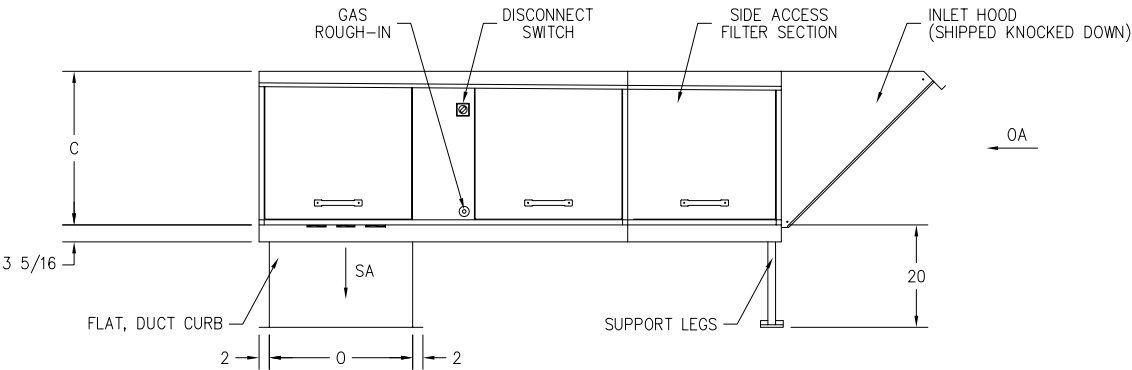

CONTROL SIDE VIEW

	V1	V2	V3	V4	V5
A	50	72	92	96	96
B	28	32	40	48	55
C	24	30	33	38	48
D	30	30	30	30	30
E	27	32	41	37-1/2	47
F	10-1/2 ²	7-3/16	9-11/16	12-1/16	14-1/8
G	12-1/2	17-5/8	20-5/8	23-7/8	26-3/4
H	13-3/8	15-7/16	17-7/8	20-7/8	26-3/4
J	8	9-1/4	10-1/2	12-1/4	13-1/2
K	22-7/8	27-7/8	34-7/8	42-7/8	52-7/8
M	24	28	36	44	51
UNIT WEIGHT	380 LBS	515 LBS	735 LBS	925 LBS	1,210 LBS
CURB WEIGHT	40 LBS	45 LBS	55 LBS	60 LBS	70 LBS



* 5496 N. RIVERVIEW DR. * KALAMAZOO, MI 49004 *

PROJECT NAME:

V-SERIES DIM. CHART

REF. NO./JOB NO.:

V1-V5

MODEL:

V1-V5

TAG:

-

DRAWN BY:

E. CLARK

DATE:

09-28-16

SCALE:

NONE

CERTIFIED BY:

DRAWING NO.:

S:\UNIT DRAWINGS\V1-V5

PRELIMINARY DRAWING

PROPRIETARY

V1 NOTES ONLY

GENERAL NOTES

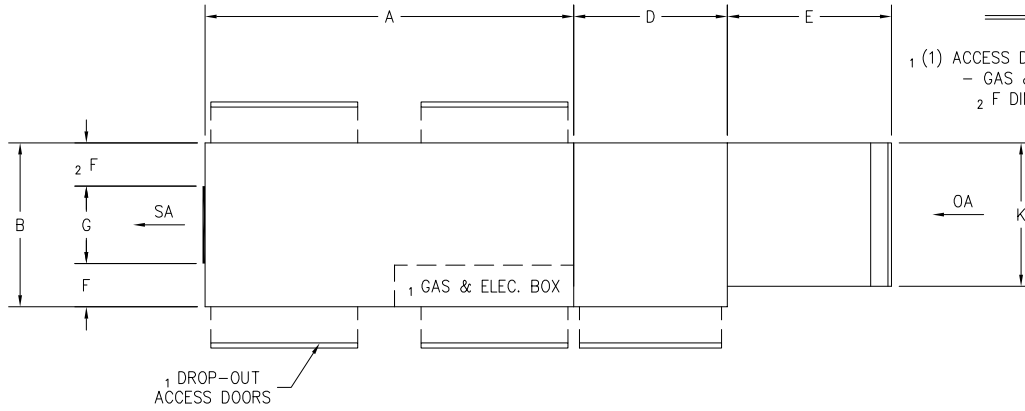

PLAN VIEW

UNLESS OTHERWISE NOTED, ALL EXTERIOR SURFACES ARE TO BE GALVANIZED STEEL.

	V1	V2	V3	V4	V5
A	50	72	92	96	96
B	28	32	40	48	55
C	24	30	33	38	48
D	30	30	30	30	30
E	27	32	41	37-1/2	47
F	10-1/2 ²	7-3/16	9-11/16	12-1/16	14-1/8
G	12-1/2	17-5/8	20-5/8	23-7/8	26-3/4
H	13-3/8	15-7/16	17-7/8	20-7/8	26-3/4
I	3-3/4	6-5/16	5-3/4	6-1/8	8-5/16
K	22-7/8	27-7/8	34-7/8	42-7/8	52-7/8
M	24	28	36	44	51
UNIT WEIGHT	380 LBS	515 LBS	735 LBS	925 LBS	1,210 LBS
CURB WEIGHT	40 LBS	45 LBS	55 LBS	60 LBS	70 LBS

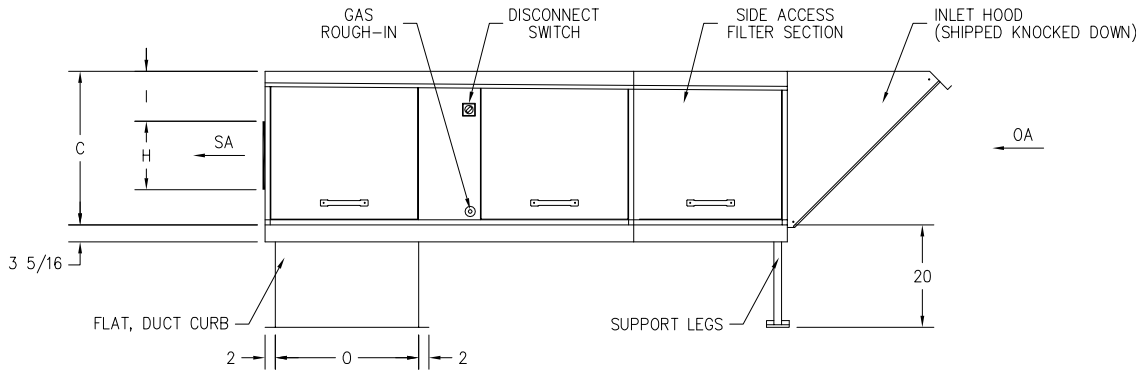

CONTROL SIDE VIEW



* 5496 N. RIVERVIEW DR. * KALAMAZOO, MI 49004 *

PROJECT NAME:

V-SERIES DIM. CHART

REF. NO./JOB NO.:

V1-V5

MODEL:

V1-V5

TAG:

-

DRAWN BY:

E. CLARK

DATE:

09-28-16

SCALE:

NONE

CERTIFIED BY:

DRAWING NO.:

S:\UNIT DRAWINGS\V1-V5

PRELIMINARY DRAWING

PROPRIETARY

V1 NOTES ONLY

GENERAL NOTES

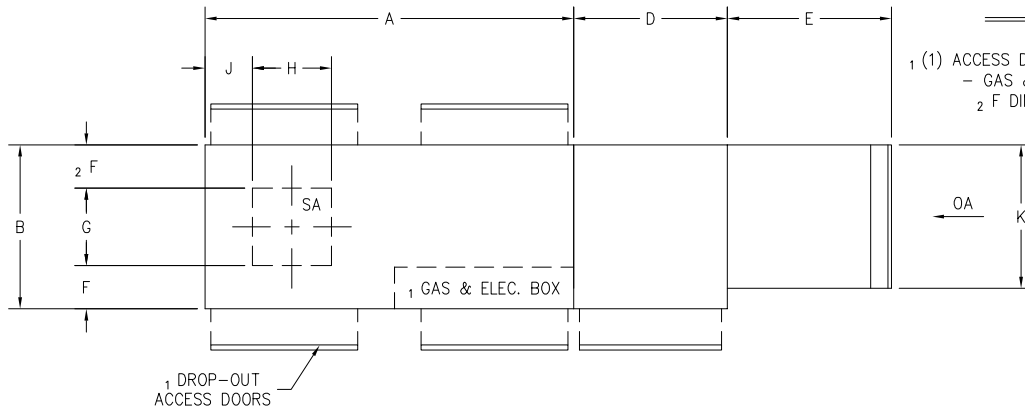

PLAN VIEW

	V1	V2	V3	V4	V5
A	50	72	92	96	96
B	28	32	40	48	55
C	24	30	33	38	48
D	30	30	30	30	30
E	27	32	41	37-1/2	47
F	10- ² / _{1-1/2}	7-3/16	9-11/16	12-1/16	14-1/8
G	12-1/2	17-5/8	20-5/8	23-7/8	26-3/4
H	13-3/8	15-7/16	17-7/8	20-7/8	26-3/4
J	8	9-1/4	10-1/2	12-1/4	13-1/2
K	22-7/8	27-7/8	34-7/8	42-7/8	52-7/8
N	76	98	118	122	122
UNIT WEIGHT	380 LBS	515 LBS	735 LBS	925 LBS	1,210 LBS
CURB WEIGHT	65 LBS	80 LBS	100 LBS	110 LBS	115 LBS

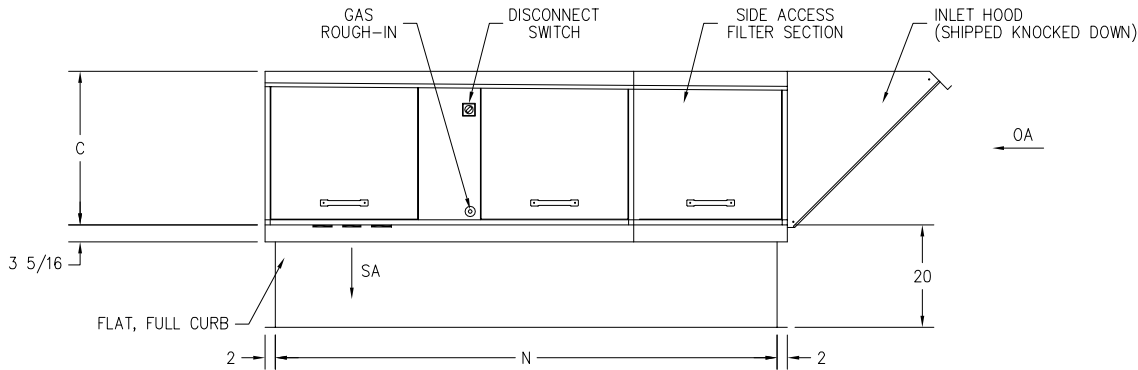

CONTROL SIDE VIEW



* 5496 N. RIVERVIEW DR. * KALAMAZOO, MI 49004 *

PROJECT NAME:

V-SERIES DIM. CHART

REF. NO./JOB NO.:

V1-V5

MODEL:

V1-V5

TAG:

-

DRAWN BY:

E. CLARK

DATE:

09-28-16

SCALE:

NONE

CERTIFIED BY:

DRAWING NO.:

S:\UNIT DRAWINGS\V1-V5

PRELIMINARY DRAWING

PROPRIETARY

V1 NOTES ONLY

GENERAL NOTES

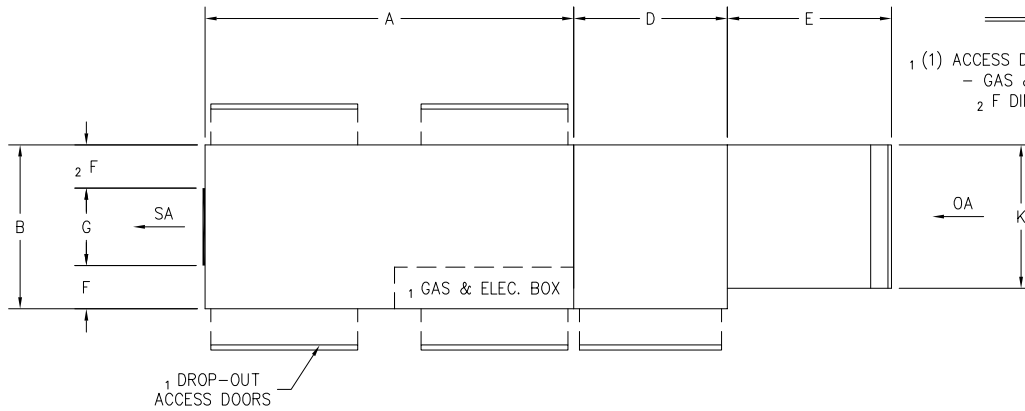

PLAN VIEW

UNLESS OTHERWISE NOTED, ALL EXTERIOR SURFACES ARE TO BE GALVANIZED STEEL.

	V1	V2	V3	V4	V5
A	50	72	92	96	96
B	28	32	40	48	55
C	24	30	33	38	48
D	30	30	30	30	30
E	27	32	41	37-1/2	47
F	10-1/2 ²	7-3/16	9-11/16	12-1/16	14-1/8
G	12-1/2	17-5/8	20-5/8	23-7/8	26-3/4
H	13-3/8	15-7/16	17-7/8	20-7/8	26-3/4
I	3-3/4	6-5/16	5-3/4	6-1/8	8-5/16
K	22-7/8	27-7/8	34-7/8	42-7/8	52-7/8
N	76	98	118	122	122
UNIT WEIGHT	380 LBS	515 LBS	735 LBS	925 LBS	1,210 LBS
CURB WEIGHT	65 LBS	80 LBS	100 LBS	110 LBS	115 LBS

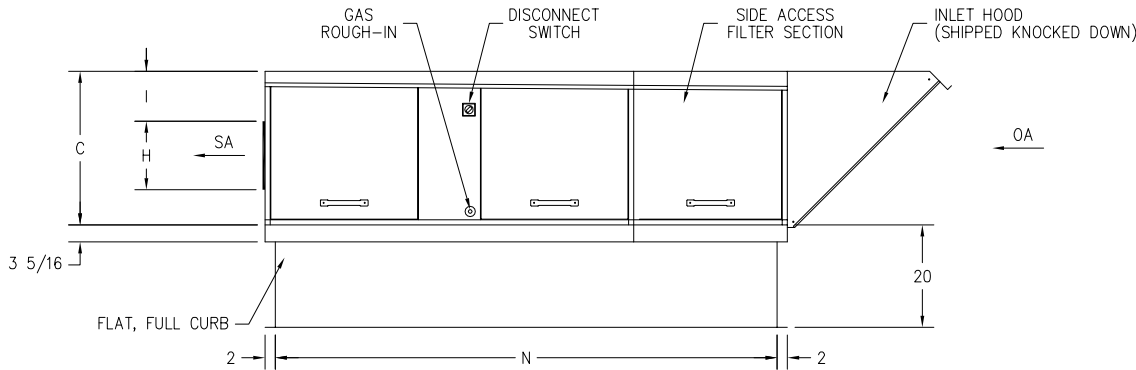

CONTROL SIDE VIEW



* 5496 N. RIVERVIEW DR. * KALAMAZOO, MI 49004 *

PROJECT NAME:

V-SERIES DIM. CHART

REF. NO./JOB NO.: V1-V5

MODEL: V1-V5

TAG: -

DRAWN BY: E. CLARK

DATE: 09-28-16

SCALE: NONE

CERTIFIED BY:

DRAWING NO.: S:\UNIT DRAWINGS\V1-V5

V-Series

Horizontal Indoor

Sizes: V1 – V5

Legend:

Down Dis: Down (Vertical) Discharge
End Dis: End (Horizontal) Discharge
Base Cab: The burner and blower section
IH: Inlet Hood with bird screen
FIH: Filtered Inlet Hood
SAFS: Side Access Filter Section
DC: Duct curb and legs
Curb: Full roof curb

PRELIMINARY DRAWING

PROPRIETARY

V1 NOTES ONLY

GENERAL NOTES

- 1 (1) ACCESS DOOR PER SIDE IN LIEU OF (2) PER SIDE AS SHOWN
- GAS & ELEC. BOX EXTENDS FULL CABINET LENGTH
- 2 F DIMENSION ON OPPOSITE CONTROL SIDE = 5"

UNLESS OTHERWISE NOTED, ALL EXTERIOR SURFACES ARE TO BE GALVANIZED STEEL.

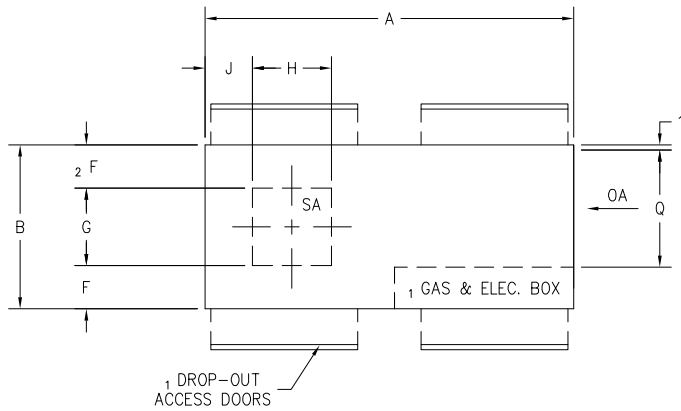

PLAN VIEW

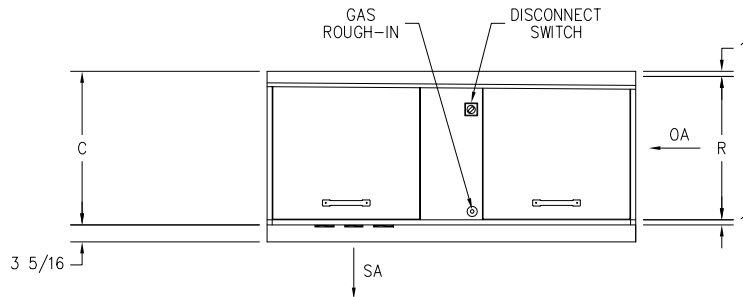

CONTROL SIDE VIEW

	V1	V2	V3	V4	V5
A	50	72	92	96	96
B	28	32	40	48	55
C	24	30	33	38	48
F	10- ² / ₁ / ₂	7-3/16	9-11/16	12-1/16	14-1/8
G	12-1/2	17-5/8	20-5/8	23-7/8	26-3/4
H	13-3/8	15-7/16	17-7/8	20-7/8	26-3/4
J	8	9-1/4	10-1/2	12-1/4	13-1/2
Q	19-7/8	22-7/8	28-7/8	36-7/8	43-7/8
R	22	28	31	36	46
UNIT WEIGHT	285 LBS	385 LBS	560 LBS	715 LBS	940 LBS
CURB WEIGHT					



* 5496 N. RIVERVIEW DR. * KALAMAZOO, MI 49004 *

PROJECT NAME:

V-SERIES DIM. CHART

REF. NO./JOB NO.: V1-V5

MODEL: V1-V5

TAG: -

DRAWN BY: E. CLARK

DATE: 09-28-16

SCALE: NONE

CERTIFIED BY:

DRAWING NO.: S:\UNIT DRAWINGS\V1-V5

PRELIMINARY DRAWING

PROPRIETARY

V1 NOTES ONLY

GENERAL NOTES

- 1 (1) ACCESS DOOR PER SIDE IN LIEU OF (2) PER SIDE AS SHOWN
- GAS & ELEC. BOX EXTENDS FULL CABINET LENGTH
- 2 F DIMENSION ON OPPOSITE CONTROL SIDE = 5"

UNLESS OTHERWISE NOTED, ALL EXTERIOR SURFACES ARE TO BE GALVANIZED STEEL.

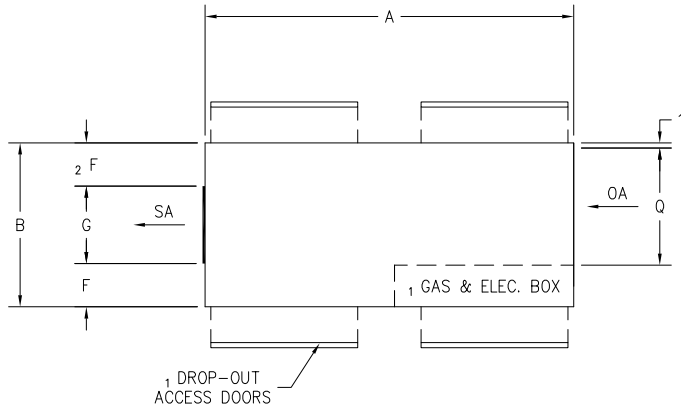

PLAN VIEW

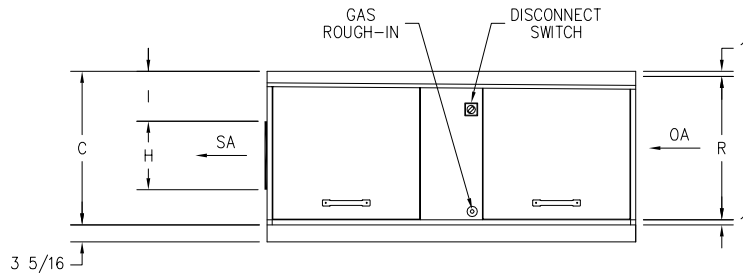

CONTROL SIDE VIEW

	V1	V2	V3	V4	V5
A	50	72	92	96	96
B	28	32	40	48	55
C	24	30	33	38	48
F	10 ² -1/2	7-3/16	9-11/16	12-1/16	14-1/8
G	12-1/2	17-5/8	20-5/8	23-7/8	26-3/4
H	13-3/8	15-7/16	17-7/8	20-7/8	26-3/4
I	3-3/4	6-5/16	5-3/4	6-1/8	8-5/16
Q	19-7/8	22-7/8	28-7/8	36-7/8	43-7/8
R	22	28	31	36	46
UNIT WEIGHT	285 LBS	385 LBS	560 LBS	715 LBS	940 LBS
CURB WEIGHT					



* 5496 N. RIVERVIEW DR. * KALAMAZOO, MI 49004 *

PROJECT NAME:

V-SERIES DIM. CHART

REF. NO./JOB NO.:

V1-V5

MODEL:

V1-V5

TAG:

-

DRAWN BY:

E. CLARK

DATE:

09-28-16

SCALE:

NONE

CERTIFIED BY:

DRAWING NO.:

S:\UNIT DRAWINGS\V1-V5

PRELIMINARY DRAWING

PROPRIETARY

V1 NOTES ONLY

- 1 (1) ACCESS DOOR PER SIDE IN LIEU OF (2) PER SIDE AS SHOWN
- GAS & ELEC. BOX EXTENDS FULL CABINET LENGTH
- 2 F DIMENSION ON OPPOSITE CONTROL SIDE = 5"

GENERAL NOTES

UNLESS OTHERWISE NOTED, ALL EXTERIOR SURFACES ARE TO BE GALVANIZED STEEL.

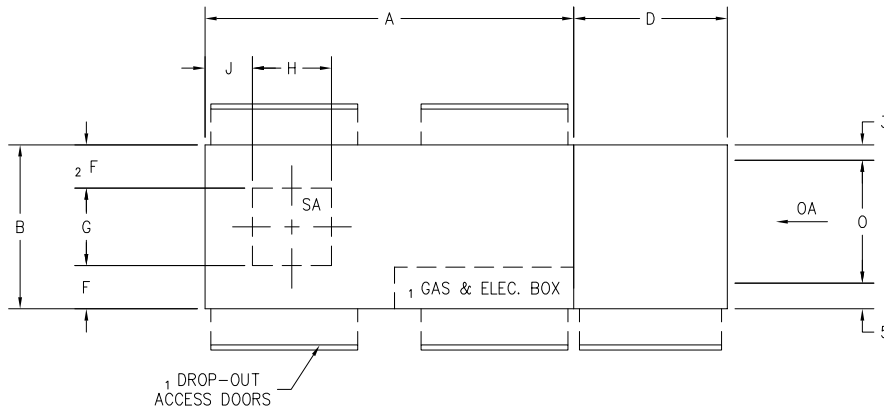

PLAN VIEW

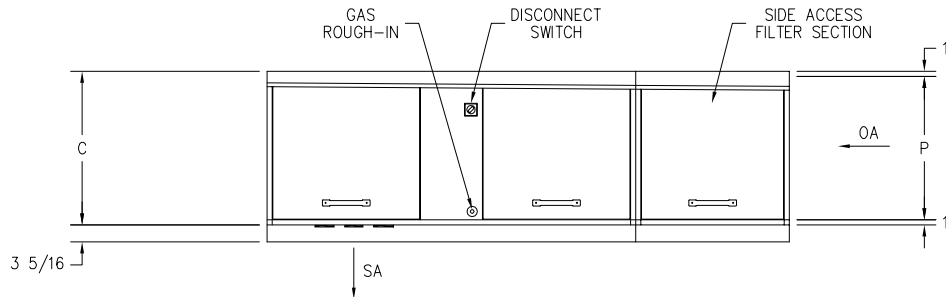

CONTROL SIDE VIEW

	V1	V2	V3	V4	V5
A	50	72	92	96	96
B	28	32	40	48	55
C	24	30	33	38	48
D	30	30	30	30	30
F	10- ² / ₁₆	7-3/16	9-11/16	12-1/16	14-1/8
G	12-1/2	17-5/8	20-5/8	23-7/8	26-3/4
H	13-3/8	15-7/16	17-7/8	20-7/8	26-3/4
J	8	9-1/4	10-1/2	12-1/4	13-1/2
O	20	24	32	40	47
P	22	28	31	36	46
UNIT WEIGHT	340 LBS	455 LBS	660 LBS	835 LBS	1,090 LBS
CURB WEIGHT					



* 5496 N. RIVERVIEW DR. * KALAMAZOO, MI 49004 *

PROJECT NAME:

V-SERIES DIM. CHART

REF. NO./JOB NO.: V1-V5

MODEL: V1-V5

TAG: -

DRAWN BY: E. CLARK

DATE: 09-28-16

SCALE: NONE

CERTIFIED BY:

DRAWING NO.: S:\UNIT DRAWINGS\V1-V5

PRELIMINARY DRAWING

PROPRIETARY

V1 NOTES ONLY

GENERAL NOTES

- 1 (1) ACCESS DOOR PER SIDE IN LIEU OF (2) PER SIDE AS SHOWN
- GAS & ELEC. BOX EXTENDS FULL CABINET LENGTH
- 2 F DIMENSION ON OPPOSITE CONTROL SIDE = 5"

UNLESS OTHERWISE NOTED, ALL EXTERIOR SURFACES ARE TO BE GALVANIZED STEEL.

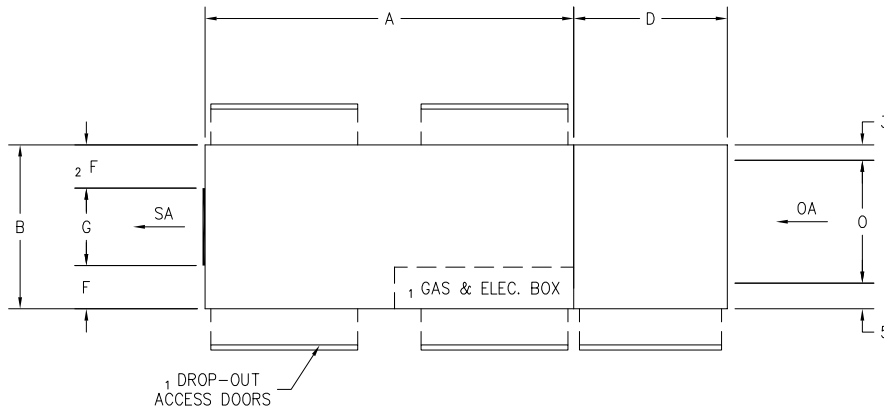

PLAN VIEW

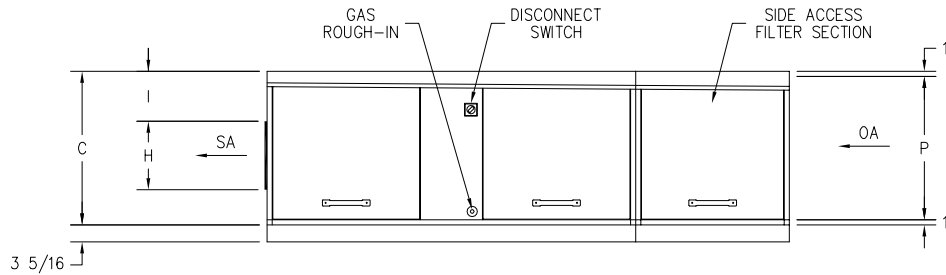

CONTROL SIDE VIEW

	V1	V2	V3	V4	V5
A	50	72	92	96	96
B	28	32	40	48	55
C	24	30	33	38	48
D	30	30	30	30	30
F	10- ² / ₁₆	7-3/16	9-11/16	12-1/16	14-1/8
G	12-1/2	17-5/8	20-5/8	23-7/8	26-3/4
H	13-3/8	15-7/16	17-7/8	20-7/8	26-3/4
I	3-3/4	6-5/16	5-3/4	6-1/8	8-5/16
O	20	24	32	40	47
P	22	28	31	36	46
UNIT WEIGHT	340 LBS	455 LBS	660 LBS	835 LBS	1,090 LBS
CURB WEIGHT					



* 5496 N. RIVERVIEW DR. * KALAMAZOO, MI 49004 *

PROJECT NAME:

V-SERIES DIM. CHART

REF. NO./JOB NO.: V1-V5

MODEL: V1-V5

TAG: -

DRAWN BY: E. CLARK

DATE: 09-28-16

SCALE: NONE

CERTIFIED BY:

DRAWING NO.: S:\UNIT DRAWINGS\V1-V5