

Product Description

The L02-02-0108 Wall Mounted RH sensor converts a resistance to a linear 0 to 10 VDC output.

The Advanced Ceramic Technology design overcomes the limitations of other resistance-based humidity sensors that utilize water soluble polymer coatings. The Advanced Ceramic Technology enables these sensors to fully recover from condensation. This allows the sensor to maintain its accuracy over a longer period of time. Despite its accuracy, the Advanced Ceramic Technology sensor and related circuitry is economical.

Field calibration is achieved by toggling either the increment or decrement dip switch. Each toggle will allow for a +/- 0.5% RH increase or decrease.

Accuracy is maintained over the operating range, using a thermistor for temperature compensation. Precision production tolerances maintain sensor interchangeability to within +/- 3% nominal without recalibration.

Each L02-02-0108 wall mounted humidity sensor is calibrated at 3 different points, using an NIST Traceable Temperature/Humidity chamber.

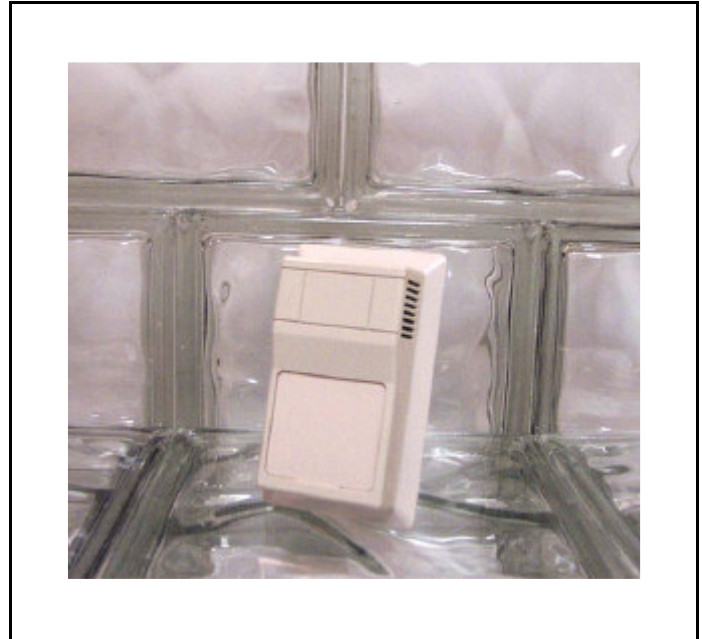

Technical Data

Supply Voltage	• 500 Ohm Load: +18 to 36 VDC / 24 VAC
Operating Temp	• -10 to 160°F (-23.3 to 71°C)
Operating RH	• 0 to 100% RH
Output	• 0-10 VDC
Interchangeability	• +/- 3% from 20 to 95% RH
Long Term Stability	• < +/- 3% RH nominal
Accuracy @ 77°F	• Less than 2% RH Drift / 5 Years
Response Time	• 30 seconds for 63% Step
Saturated Response Time	• 10 minutes for 63% Step
Sensitivity	• 0.1% RH
Repeatability	• 0.5% RH
Hysteresis	• Less than 0.4% RH

Device Detail

Dimensions

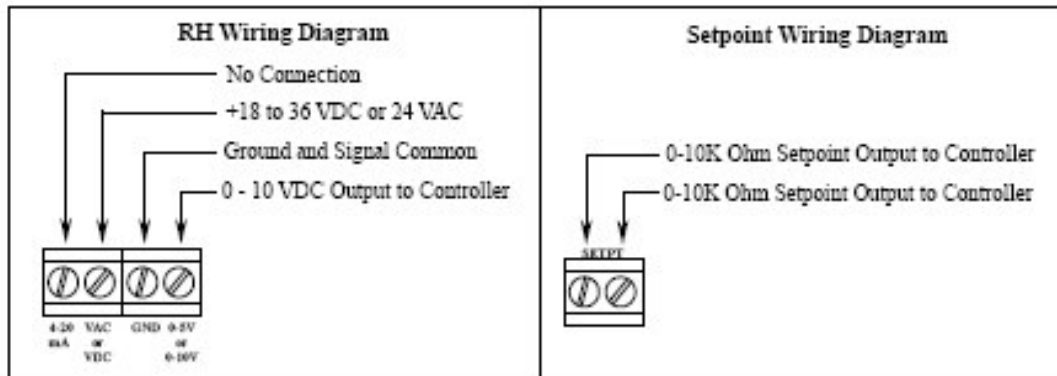
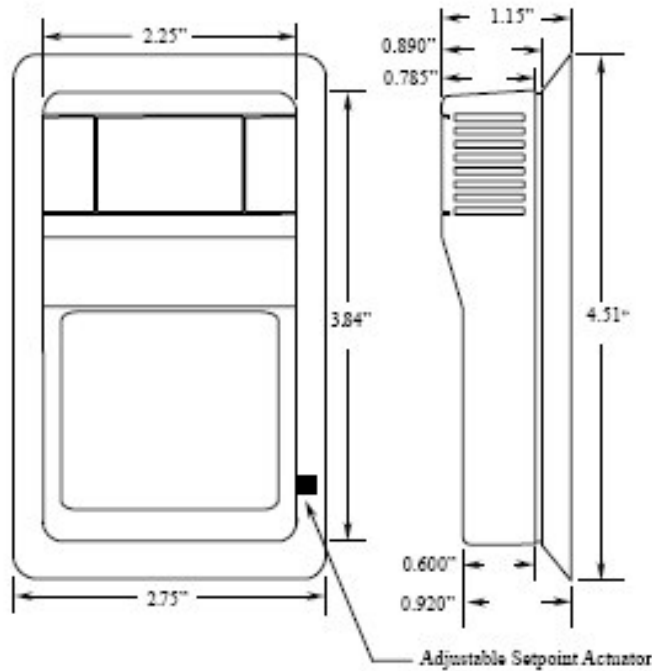

Ordering Information

Model #	Description
L02-02-0108	RH Wall Mount Sensor with Set Point Adjustment