



Model No. RDU

Support 877-351-4702

DIGITAL SET POINT SPACE TEMPERATURE CONTROL INSTALLATION, OPERATION, AND MAINTENANCE MANUAL



This manual covers the following products:

- RDU Digital set point space temperature control
- STS-1 Wall mount space temperature sensor 20-140°F (4-60°C)
- STS-2 Probe mount space temperature sensor 20-250°F (4-121°C)
- BAT AA Lithium Battery

Table of Contents

Overview.....	2
Specifications	2
Installation	3
Control Modes.....	4
Normal Operation.....	4
Programming.....	5
Menu Map	5

Overview

The Remote Display Unit (RDU) is a digital set point space temperature control. It is compatible with the DFC-X, and provides up to three set point temperatures. The control has a simple five button interface with a four digit LCD display. There are three basic modes that can be used (refer to Control Modes page 4). The RDU has one integrated temperature sensor. One external temperature sensor can be connected to provide local, remote, or average temperature sensing operation from 40°F (4°C) to 250°F (121°C). All programmable parameters can be accessed through the user menu with the five button interface and LCD display. The RDU is powered by one AA battery providing up to 2 years of operation. When the RDU has a low battery it will signal the text bAtt, which will flash on the LCD every 10 seconds. User parameters are stored in non-volatile memory, and are retained even during a battery disconnection. Switching between different pre-programmed setpoints is accomplished in programming mode or manually by providing external switched inputs as shown in Figure 1.

Figure 1

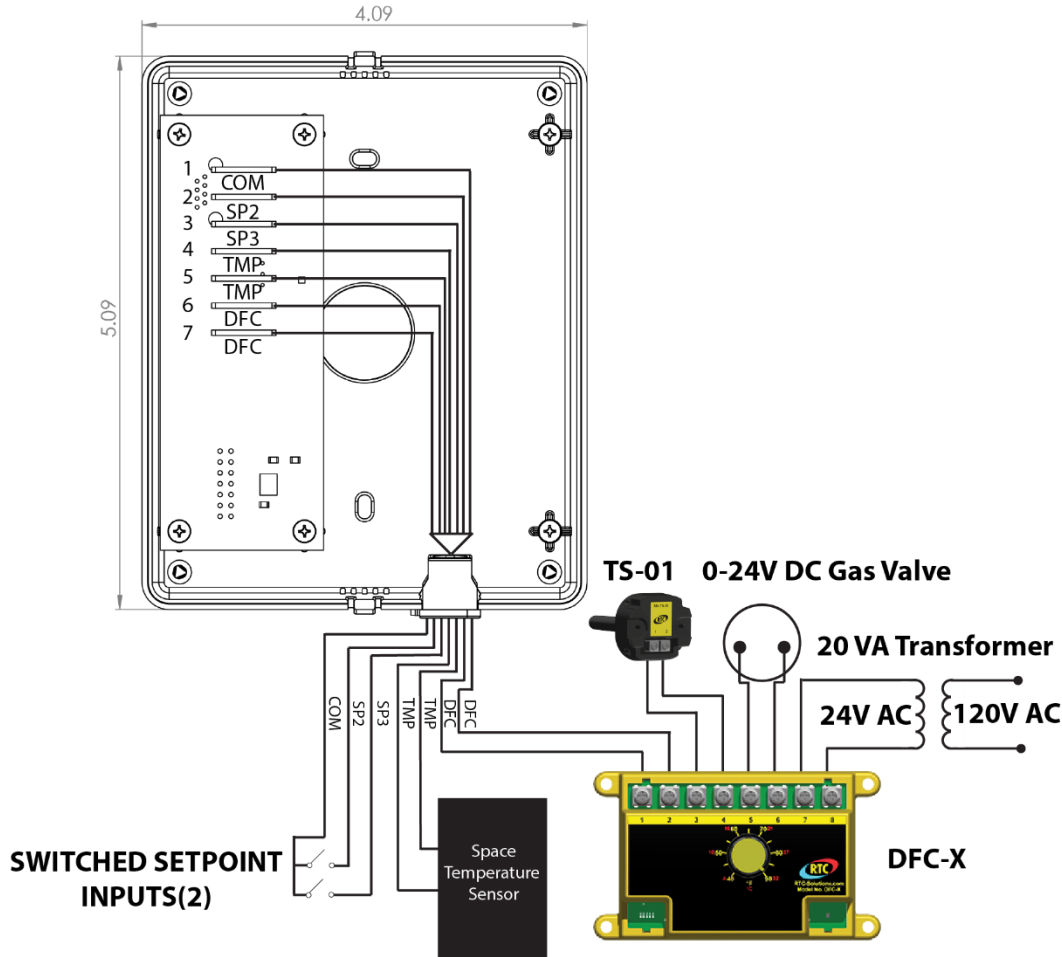

Specifications

Power Requirements

One Battery Lithium AA (1.5V)

RDU Ambient Temperature Limits

Storage

-40-140°F (-40-60°C)

Operating

40-120°F (4-48°C)

STS-1 Ambient Temperature Limits(1K PRTD)

-40-140°F (-40-60°C)

Storage

-40-140°F (-40-60°C)

Operating

STS-2 Ambient Temperature Limits(1K PRTD)

-40-250°F (-40-121°C)

-40-250°F (-40-121°C)

Installation

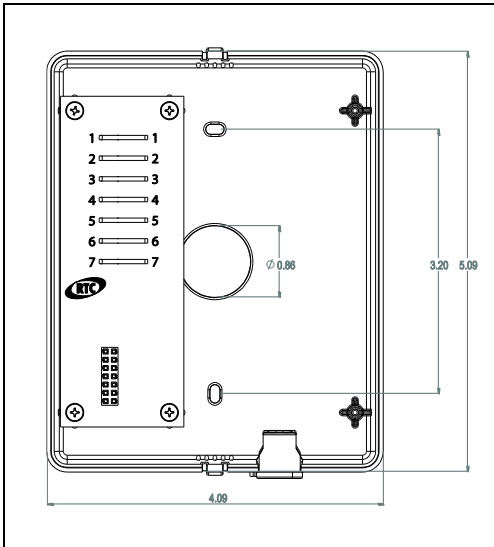

Figure 2: RDU Back Panel with dimensions

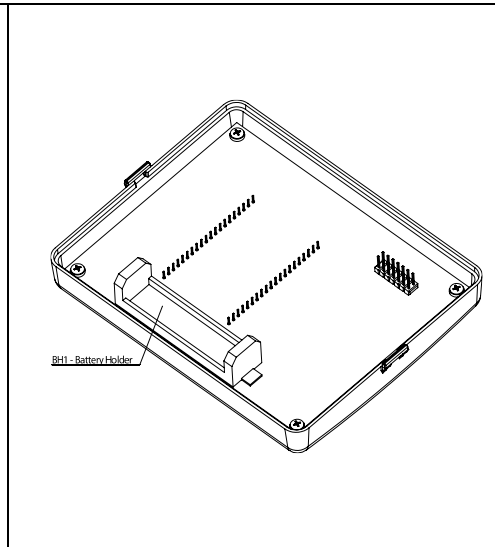

Figure 3: RDU Battery Installation

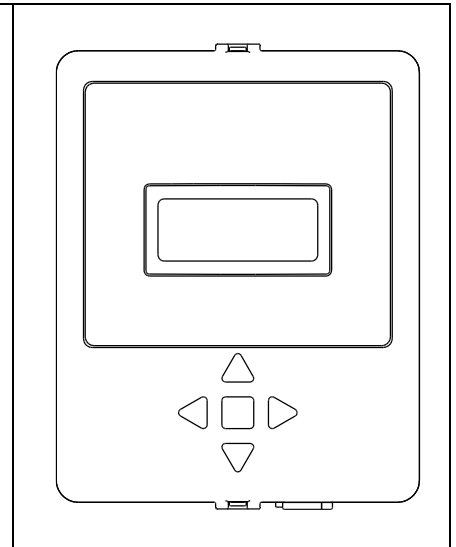

Figure 4: RDU Front Panel

The RDU may be directly wall mounted, attached to a conduit box, or used as a pendant. Mount and wire the back panel according to figure 2. Refer to figure 1 for complete details.

Wiring:

- | | | |
|---|-----|--|
| 1 | COM | Common connection for external set point switches |
| 2 | SP2 | Switch input for set point 2 |
| 3 | SP3 | Switch input for set point 3 or Remote switch to alternate between Space Mode and Discharge Mode |
| 4 | TMP | External temperature sensor input |
| 5 | TMP | External temperature sensor input |
| 6 | DFC | Output to DFC terminal 1 or 2 |
| 7 | DFC | Output to DFC terminal 1 or 2 |

Insert the supplied AA Lithium Battery into the battery holder located behind the front panel, which may be accessed by separating the RDU as shown in figure 3. Check to see if there is power to the LCD. Securely snap the front panel to the back panel, ensuring that the front panel is oriented as shown in figure 4. Refer to page 5 for Programming.

A strain relief may be added where a multi-wire cord is used.

Recommended strain relief:



Heyco Products, Inc.
 Manufacturer Part #: 1832
 Description: Cable Mounting

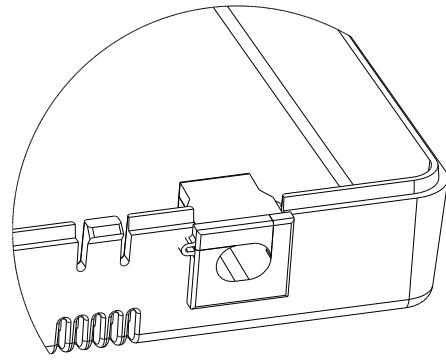
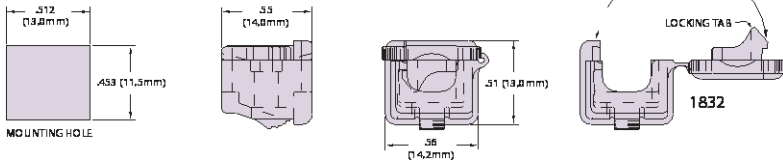

Figure 5: Strain Relief

Control Modes

In discharge mode (diS), the output is driven directly by the setpoint temperature. In space mode (SPC), the control displays the current temperature in the space, and toggles the output between dLo, the current setpoint, and dHi to drive the space temperature to the current setpoint as shown in figure 6. In discharge with temperature display mode (dtd), the output is driven directly by the setpoint as in discharge mode, but the control displays the current temperature measured by either the onboard or remote sensor.

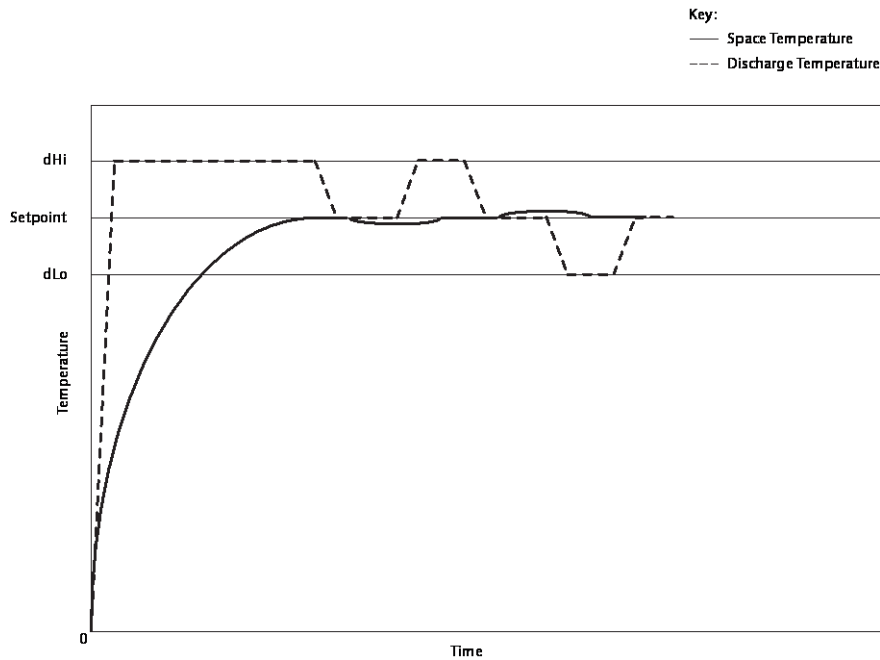
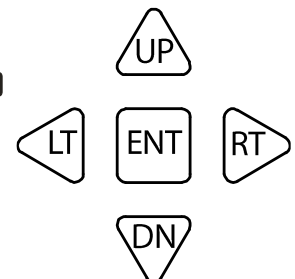

Figure 6: Space Mode

Normal Operation

Press any arrow key to change the temperature. Once an arrow key is pressed, the LCD will blink with the text for the current setpoint (ex: SP1). Use the **RT** or **LT** keys to navigate to one of three desired setpoints. When the preferred setpoint to edit is blinking, use the **UP** or **DN** keys to select a new temperature. Press the **ENT** key to save the changes made. The LCD will display either the setpoint, or the current measured temperature, depending on the mode of operation. If a key is not pressed for 10 seconds, the RDU will exit without saving.



After adjusting and saving a setpoint, the RDU will use the current setpoint based on the switch selected. For example, if the temperature for SP2 is edited and saved, but the switch for SP3 is selected on the terminal strip, then the RDU will use SP3 even though changes were made to SP2. When adjusting a setpoint range, the setpoint cannot surpass the set Low and High values. For instance, If Lo1 is set to 80°F and hi1 is set to 150°F, SP1 is only adjustable between 80°F to 150°F.

Figure 7: RDU Keys

Setpoints:

SP1 is selected when no connection is made to SP2 and SP3.

SP2 is selected by making the connection between COM on the terminal strip and SP2.

SP3 is selected by making the connection between COM on the terminal strip and SP3.

Programming

To enter program mode, hold the **ENT** key down for 3 seconds. If the control is password protected the display will show PASS, otherwise the display will show Lo1. If password protected, no menu settings may be altered until the password is entered. Press the **ENT** key and use the **UPA** and **DNV** keys to set the display to the factory set password (21). Press the **ENT** key again to access the menu map as shown on page 5. Once in the program mode, use the **UPA** and **DNV** keys to navigate to the desired menu parameter as shown in column 1. To edit a menu parameter, press the **RT▶** key once on the desired parameter, and the display will blink the current value of that parameter as shown in column 2. Use the **UPA** and **DNV** keys again to edit the parameters for column 2. Press the **ENT** key to save the changes made or the **LT◀** key to cancel without saving and return to column 1. To enable the password, navigate to the PASS parameter and set to EnAb. If a key is not pressed for 10 seconds the control will automatically return to normal mode. Different parameters are as follows:

1. "Lo(X)": Sets the lowest point the user can adjust the temperature to, outside of programming mode. Low (Lo(X)) can be set from 40°F - 240 °F and must be at least 10°F less than the High.
2. "Hi(X)": Sets the highest point the user can adjust the temperature to, outside of programming mode. High (hi(X)) can set be from 50°F - 250°F and must be at least 10°F greater than the Low.
3. "SP(X)": Adjusts the discharge setpoint. Setpoint (SP) may be adjusted within the menu map or on the main screen with the up and down arrows, then pressing enter to save the selected setpoint. When adjusting the discharge setpoint temperature above the outside air temperature, it will result in turning the burner on and modulating the system at that specified setpoint.
4. "dLo": Sets the low discharge temperature for SPACE mode. The Low discharge limit (dLo) can be set from 40°F - 240°F and must be at least 10°F less than the High discharge limit (dhi). This will limit the discharge temperature of the heater during space control mode.
5. "dhi": Sets the high discharge temperature for SPACE mode. The High discharge limit can be set from 50°F - 250°F and must be at least 10°F greater than the Low. This will limit the discharge temperature of the heater during space control mode.
6. "oPr": Sets the control operating mode. In discharge mode (diS), the output is driven directly by the setpoint temperature. In space mode (SPC), the control displays the current temperature in the space, and toggles the output between dLo, the current setpoint, and dhi to drive the space temperature to the current setpoint. In remote mode (re) the control will operate off of a remote switch allowing the user to alternate between discharge mode and space mode.
7. "SEn": Sets the temperature sensor location. The temperature sensor used for "space mode" and "discharge with temperature display mode" may be set to use the onboard or local (LoC) sensor, the remote (rE) sensor, or they may be averaged (AvG).
8. "oS": Sets a temperature offset to correct for things like duct losses or sensor calibration errors.
9. "ForC": Sets the control to display °F or °C.
10. "PASS": By default the password option is disabled. Beyond that there are two levels of protection. Level 1 only allows the user to change multiple setpoints. Level 2 protection prohibits the user from editing all parameters.
11. "VER": View the current software version.

Arrow Keys

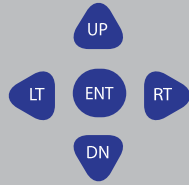

Up and Down: to navigate or adjust a menu parameter

Right: to access column 2 for editing a parameter

Left: to return to column 1 without saving a parameter

Enter: to return to column 1 while saving a parameter

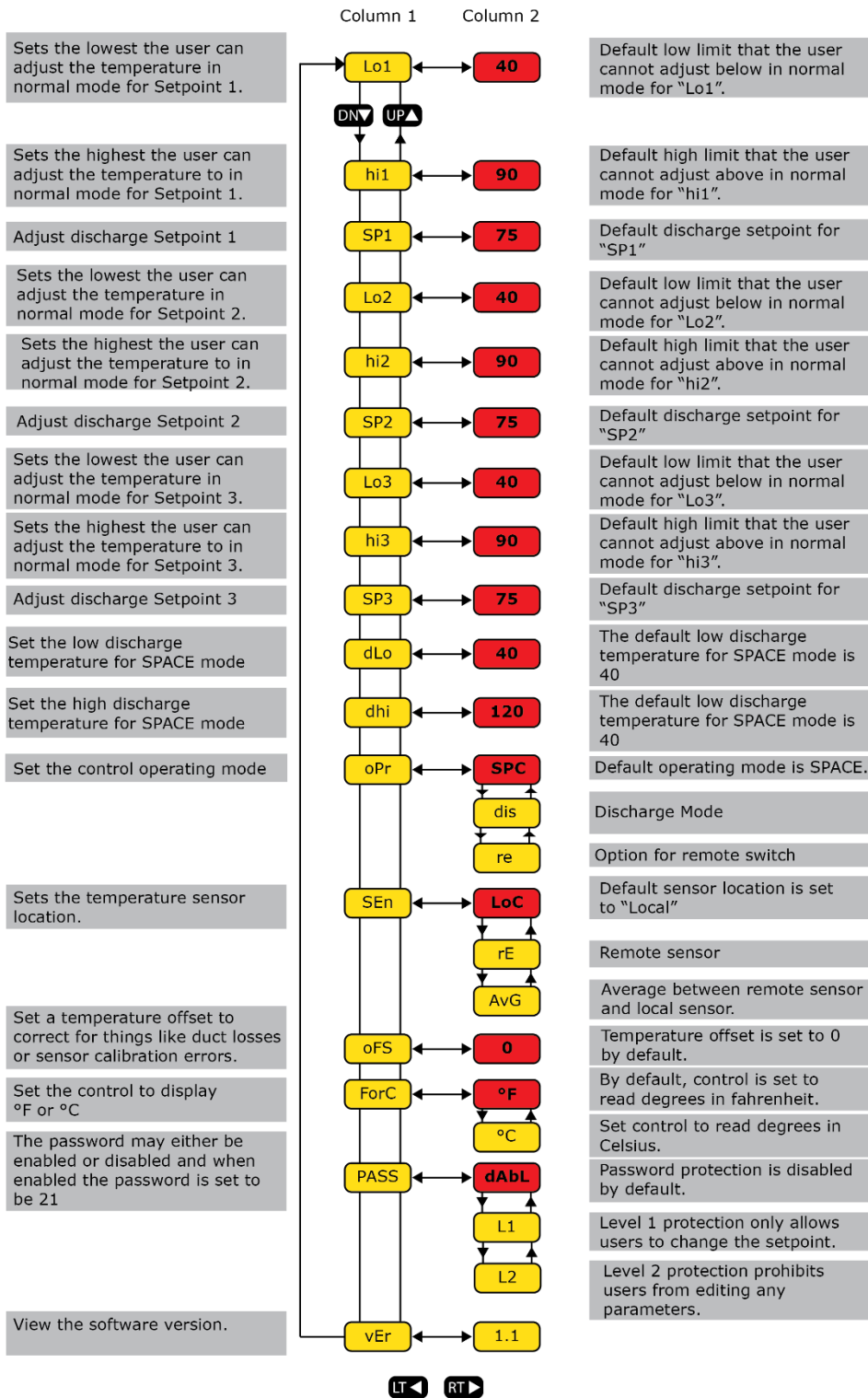

RDU Menu Map

(Red indicates default parameter)