

**REVISED**

10:33 am, Aug 14, 2007

**INSTALLATION AND MAINTENANCE INSTRUCTIONS**

**Duct Smoke Detector with Extended Air Speed Range, D4S Air Duct Smoke Detector Sensor Component, D4P120 Air Duct Smoke Detector Power Board Component**



**SYSTEM SENSOR**

3825 Ohio Avenue, St. Charles, Illinois 60174  
1-800-SENSOR2, FAX: 630-377-6495  
www.systemsensor.com

156-2967-000R

**NOTE:** D4S Sensor Component and D4P120 Power Board Component to be used in conjunction with the model D4120 air duct smoke detector only.

**Specifications**

Operating Temperature:	-4° to 158° F (-20° to 70° C)
Storage Temperature:	-22° to 158° F (-30° to 70° C)
Humidity:	0% to 95% R.H. non-condensing
Air Velocity:	100 to 4000 ft./min. (0.5 to 20.3 m/sec.)
D4120 Footprint Dimensions:	Rectangular - 14.38" L x 5" W x 2.5" D (37cm L x 12.7cm W x 6.36cm D) Square - 7.75" L x 9" W x 2.5" D (19.7cm L x 22.9cm W x 6.35cm D)
D4S/D4P120 Footprint Dimensions:	7.75" L x 5" W x 2.5" D (19.7cm L x 12.7cm W x 6.35cm D)
D4120 Weight:	2.5 pounds; 1.14 kg

**Electrical**

Power supply voltage:	20-29 VDC	24 VAC 50-60-Hz	120 VAC 50-60 Hz
Input capacitance:	270 µF max.	270 µF max.	N/A
Reset Voltage:	3.0 VDC min.	2.0 VAC min.	10 VAC min.
Reset Time (with RTS451):	.03 to 0.3 sec.	.03 to 0.3 sec.	.03 to 0.3 sec.
Reset Time (by power down):	0.6 sec. max.	0.6 sec. max.	0.6 sec. max.
Power Up Time:	35 sec. max.	35 sec. max.	35 sec. max.
Alarm response time:	15 sec.	15 sec.	15 sec.
Sensitivity Test:	See detector label	See detector label	See detector label
<b>Current Requirements (Using No Accessories)</b>			
Max. standby current	25 mA @ 24 VDC	55 mA RMS @ 24VAC 60Hz	20 mA RMS* @ 120 VAC 60 Hz
Max. alarm current	60 mA @ 24 VDC	130 mA RMS @ 24 VAC 60 Hz	35 mA RMS* @ 120 VAC 60 Hz

**CONTACT RATINGS**

Alarm initiation contacts (SPST)	2.0A @ 30 VDC (resistive)
Alarm auxiliary contacts (DPDT)	10A @30 VDC (resistive) 10A @250 VAC (resistive) 1/2 HP @240 VAC 1/4 HP @ 120 VAC
NOTE: Alarm auxiliary contacts shall not be connected to initiating circuits of control panels. Use the alarm initiation contact for this purpose.	
Trouble Contacts (SPDT)	2.0A @ 30 VDC (resistive) 2.0A @ 125 VAC (resistive)

**ACCESSORY CURRENT LOADS AT 24 VDC**

DEVICE	STANDBY	TROUBLE	ALARM
APA151/APA451	12.5mA	n/a	30mA Max.
MHR/MHW	0mA	n/a	29mA Max.
RA400Z	0mA	n/a	10mA Max.
RTS451	0mA	n/a	7.5mA Max.
RTS451KEY	12mA*	n/a	7.5mA Max.
SSK451	5mA Max.	9mA Max.	30mA Max.

\*NOTE: When a unit is powered at the 120VAC input, any combination of accessories may be used such that the given accessory loads are: 60mA or less in the standby state, 110mA or less in the alarm state.

**TABLE 1. Detector Status Indications**

Status	Sensor LED Designation	Power Board LED Designation	Description/Trouble Shooting
Sensor Initialization	Red Blink every 5 seconds	Alternating Green/Amber	At power up or reset at the panel the sensor will take approximately 30 seconds to initialize. Also occurs when sensor is removed during a seven minute delay.
Standby	Green Blink every 5 seconds	Green Blink every 5 seconds	The LED on the sensor and the power board should flash approximately every 5 seconds. If the detector and power board LEDs are not illuminated, then the detector lacks power (check wiring, panel or power supply).
Trouble	Green Blink every 5 seconds	Amber Solid	The cover has been missing or is not secured properly for more than 7 minutes, if the cover tamper feature is "ON" (factory default). See <b>Figure 13</b> . OR Sensor +, - wires are shorted. Check connections. NOTE: If the power board Solid Amber flashes once every ten seconds the unit is not receiving valid data from sensor. Ensure the sensor is secured in place and the sensor +, - wires are properly connected.
Maintenance	Red Blink every 5 seconds	Amber Blink	The sensor is outside of its sensitivity limits and shall be cleaned or replaced. See section 9 for details.
Alarm	Solid Red	Solid Red	The unit is in alarm.

**NOTE:** Each power board has a unique LED to designate each of 2 possible sensors. If only one sensor is connected, the Sensor 2 LED will not illuminate.

**Table of Contents**

[1] Exploded View of Duct Smoke Detector Components . . . . .	2
[2] General Description . . . . .	2
[3] Limitations of Duct Smoke Detectors . . . . .	2
[4] Contents of Duct Smoke Detector Kit . . . . .	2
[5] Detector Installation . . . . .	2
[6] Sampling Tube Installation . . . . .	3

**Page**

**Table of Contents**

[7] Field Wiring . . . . .	4
[8] Duct Smoke Detector Testing & Maintenance . . . . .	4
[9] Detector Cleaning . . . . .	5
[10] Sensor Placement . . . . .	5
Wiring Diagrams . . . . .	6-8
Warranty . . . . .	8

**Page**

**[1] Figure 1. Exploded View of Duct Smoke Detector Components:**

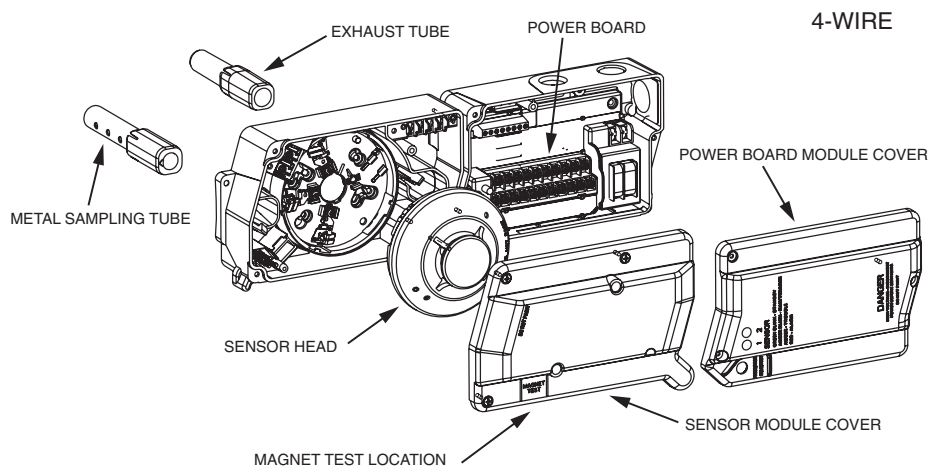

H0549-00

**Before Installing**

Read the System Sensor Guide for Proper Use of Smoke Detectors in Duct Applications (A05-1004), which provides information on detector spacing, placement, zoning, wiring, and special applications. This manual is available online at [www.systemsensor.com](http://www.systemsensor.com). NFPA Standards 72 and 90A should also be referenced for detailed information.

**NOTICE:** This manual shall be left with the owner/user of this equipment.

**IMPORTANT:** This detector must be tested and maintained regularly following NFPA 72 requirements. The detector should be cleaned at least once a year.

**[2] General Description**

Smoke introduced into an air duct system will be distributed throughout the entire building. Smoke detectors designed for use in air duct systems are used to sense the presence of smoke in the duct.

Model D4120 and D4S Duct Smoke Detectors utilize 4-wire photoelectric technology for the detection of smoke. This detection method, when combined with an efficient housing, samples air passing through the duct allowing detection of a developing hazardous condition. When sufficient smoke is sensed, an alarm signal is initiated and appropriate action can be taken to shut off fans, blowers, change over air handling systems, etc. These actions can facilitate the management of toxic smoke and fire gases throughout the areas served by the duct system.

The D4120, D4P120 and D4S detectors are designed to operate on 24 VDC/VAC or 120 VAC. Alarm and supervisory relay contacts are available for control panel interface (alarm initiation), HVAC control, and other auxiliary functions. Auxiliary relays are provided for fan shut down. Detector interconnection provides signaling of up to 50 other detectors in the loop for multiple fan shut down. These detectors are not designed for 2-wire applications.

For testing, the alarm can be enabled by a test button on the power board cover, magnet activated test switch or by the optional remote test station. The duct smoke detector latches into alarm state when an alarm occurs. The D4120 and D4P120 LEDs indicate the status of power, maintenance, trouble, and local alarm conditions.

The D4120 and D4P120 can be reset by a momentary power interruption, the reset button on the front cover, the control panel, or remote reset accessory. **The D4120 and D4P120 incorporate a cover tamper feature that provides a trouble signal after 7 minutes if the cover is removed or improperly installed.** The option for an instantaneous trouble is also available. Proper installation of the cover removes the trouble condition.

**[3] Limitations Of Duct Smoke Detectors**



The National Fire Protection Association has established that DUCT DETECTORS MUST NOT BE USED AS A SUBSTITUTE FOR OPEN AREA DETECTOR PROTECTION as a means of providing life safety. Nor are they a substitute for early warning in a building's regular fire detection system.

System Sensor supports this position and strongly recommends that the SS-300-000

user read NFPA Standards 90A, 72, and 101. The D4120 Air Duct Smoke Detectors are listed per UL 268A.

This device will not operate without electrical power. Fire situations may cause an interruption of power. The system safeguards should be discussed with your local fire protection specialist.

This device will not sense smoke unless the ventilation system is operating and the cover is installed.

For this detector to function properly, it MUST be installed according to the instructions in this manual. Furthermore, the detector MUST be operated within ALL electrical and environmental specifications listed in this manual. Failure to comply with these requirements may prevent the detector from activating when smoke is present in the air duct.

**[4] Contents Of The Duct Smoke Detector Kit**

1. Sensor/power board assembly and covers
2. Three #10 sheet metal screws for mounting
3. One test magnet
4. Drilling template
5. One sampling tube end cap
6. One plastic exhaust tube

**NOTE:** A sampling tube must be ordered to complete the installation. It must be the correct length for the width of the duct where it will be installed. See Table 2 on page 3 to determine the inlet tube required for different duct widths.

**[5] Detector Installation**

**[5.1] Verify Air Flow Direction And Velocity**

Model D4120 detectors are designed to be used in air handling systems with air velocities of 100 to 4000 feet per minute. Duct widths from 6in. to 12ft. can be accommodated. Be sure to check engineering specifications to ensure that the air velocity in the duct falls within these parameters. If necessary, use a velocity meter (anemometer) to check the air velocity in the duct.

**[5.2] Determine Mounting location and Configuration**

On ducts wider than 18" it is recommended that the detector be mounted downstream of a bend, obstruction in the duct, or the supply or return air inlet.

Exception: Installation of duct detectors can be on or within a commercial packaged rooftop heating and air-conditioning system, fire/smoke dampers and economizers. They may be mounted in either the supply and/or return air section as determined by local code.

Once a suitable location is selected, determine if the detector is to be mounted in a side-by-side "rectangular" configuration or a top-over-bottom "square" configuration as shown in **Figure 2**. If mounting in the square configuration, remove the rear attachment screw, rotate the unit at the hinge, and replace the screw into the new attachment hole as shown in **Figure 2**. Do NOT remove the hinge screw during this process. Final installation approval shall be based upon passing section 8.2.2 and 8.2.4 tests.

**Figure 2:**

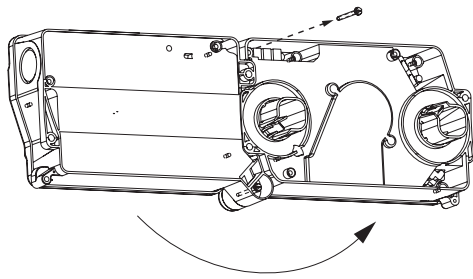

REMOVE SCREW AND PIVOT DETECTOR AS SHOWN ABOVE.

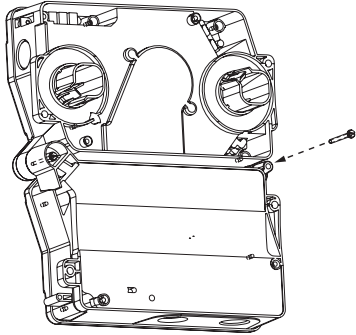

REPLACE SCREW TO SECURE DETECTOR IN PLACE.

H0550-00

**[5.3] Drill the Mounting Holes**

Remove the paper backing from the mounting template supplied. Affix the template to the duct at the desired mounting location. Make sure the template lies flat and smooth on the duct.

**[5.3.1] For rectangular side-by-side mounting configuration:**

Center punch at (4) target centers: (2) "A" for sampling tubes and (2) "B" for the rectangular configuration mounting tabs as shown on mounting template. Drill pilot holes at target "A" centers and cut two 1.375" diameter holes using a 1 3/8" hole saw or punch. Drill .156" diameter holes using a 5/32" drill at target "B" centers.

**[5.3.2] For square top-over-bottom mounting configuration or D4S sensor component mounting:**

Center punch at (4) target centers: (2) "A" for sampling tubes and (2) "C" for the square configuration mounting tabs as shown on mounting template. Drill pilot holes at target "A" centers and cut two 1.375" diameter holes using a 1 3/8" hole saw or punch. Drill .156" diameter holes using a 5/32" drill at target "C" centers. If desired, drill an additional .156" hole at the location of one of the mounting tabs on the lower housing.

**[5.4] Secure the Duct Detector to the Duct**

Use two (rectangular configuration) or three (square configuration) of the provided sheet metal screws to screw the duct detector to the duct.

**CAUTION:** Do not overtighten the screws.

**[6] Sampling Tube Installation**

**[6.1] Sampling Tube Selection**

The sampling tube must be purchased separately. Order the correct length, as specified in Table 2, for width of the duct where it will be installed. It is recommended that the sampling tube length extend at least 2/3 across the duct width for optimal performance.

**Table 2. Sampling tubes recommended for different duct widths:**

Outside Duct Width	Sampling Tube Recommended*
Up to 1 ft.	DST1
1 to 2 ft.	DST1.5
2 to 4 ft.	DST3
4 to 8 ft.	DST5
8 to 12 ft.	DST10 (2-piece)

\*Must extend a minimum of 2/3 the duct width

The sampling tube is always installed with the air inlet holes facing into the air flow. To assist proper installation, the tube's connector is marked with an arrow. Make sure the sampling tube is mounted so that the arrow points into the airflow as shown in **Figure 3**. Mounting the detector housing in a vertical orientation is acceptable provided that the air flows directly into the sampling tube holes as indicated in **Figure 3**. The sampling tube and exhaust tube can be mounted in either housing connection as long as the exhaust tube is mounted downstream from the sampling tube.

**Figure 3. Air duct detector sampling tube:**

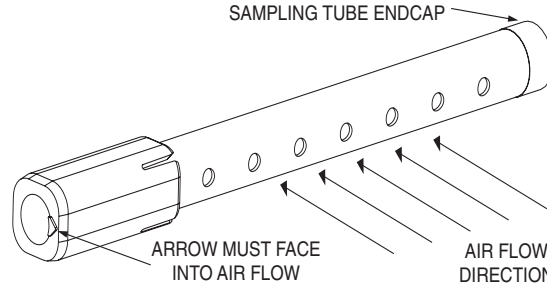

H0551-00

**NOTE:** The sampling tube end cap, included with the detector, is critical to proper operation of the duct smoke detector. The end cap is needed to create the proper air flow to the sensor of the duct smoke detector. Once any sampling tube length adjustments are made, plug the end of the sampling tube with the provided end cap.

A plastic exhaust tube is included with the unit to be installed if needed. Install into the housing connection that is downstream from the sampling tube connection. The exhaust tube can be installed from the front or back of the detector. A longer 1 foot exhaust tube, model ETX, is available as an accessory in cases where the molded exhaust tube does not extend at least 2 inches into the duct.

**[6.2] Sampling Tube Installation**

- For tubes shorter than the width of the duct, slide the sampling tube, with installed end cap, into the housing connection that meets the airflow first. Position the tube so the arrow points into the airflow as shown in **Figure 3**. Per NFPA sampling tubes over 3 feet long should be supported at the end opposite the duct detector. In ducts wider than 8 feet, work must be performed inside the duct to couple the other section of the sampling tube to the section already installed using the 1/2" conduit fitting supplied. Make sure that the holes on both sections of the air inlet sampling tube are lined up and facing into the airflow.
- For tubes longer than the width of the duct, the tube should extend out of the opposite side of the duct. Drill a 3/4" hole in the duct opposite the hole already cut for the sampling tube. Make sure the hole is 1"-2" below the inlet hole on the opposite side of the duct as shown in **Figure 4** to allow moisture drainage away from the detector. There should be 10 to 12 holes spaced as evenly as possible across the width of the duct. If there are more than 2 holes in the section of the tube extending out of the duct, select a shorter tube using Table 1. Otherwise, trim the tube to leave approximately 1" to 2" extending outside the duct. Plug the end with the end cap and tape closed any holes in the protruding section of tube. Be sure to seal the duct where the tube protrudes.

**Figure 4.**

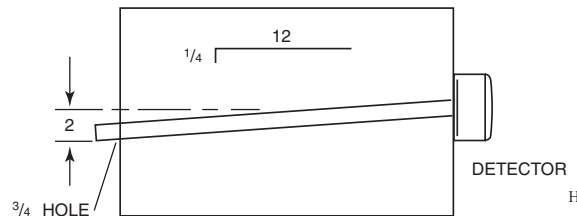

H0215-00

**NOTE:** Air currents inside the duct may cause excessive vibration, especially when the longer sampling tubes are used. In these cases, a 3" floor flange (available at most plumbing supply stores) may be used to fasten the sampling tube to the other side of the duct. When using the flange/connector mounting technique, drill a 1" to 1 1/4" hole where the flange will be used.

**[6.3] Modifications of Sampling Tubes**

There may be applications where duct widths are not what is specified for the installation. In such cases, it is permissible to modify a sampling tube that is longer than necessary to span the duct width.

Use a 0.193-inch diameter (#10) drill and add the appropriate number of holes so that the total number of holes exposed to the air flow in the duct is 10 to 12. Space the additional holes as evenly as possible over the length of the tube.

**NOTE:** This procedure should only be used as a temporary fix and is not intended as a substitute for ordering the correct length tubes.

**[6.4] Remote Sampling Tube Installation**

The detector arrangement can also incorporate remote mounting of the sampling tube and/or exhaust tube. In this case both the detector, sampling tube and exhaust tube (if included) should be rigidly mounted to withstand the pressure and vibrations caused by the air velocity. The location of the detector’s sampling tube should be such that there is uniform airflow in the cross section area.

The pressure differential across the sampling and exhaust ports in the detector housing shall be verified to be between .0015 and 1.2 inches of water. Do so by measuring the pressure difference between the inlet and outlet ports on the detector housing using a manometer as described in Section 8.2.1.

**[7] Field Wiring Installation Guidelines**

All wiring must be installed in compliance with the National Electrical Code and the local codes having jurisdiction. Proper wire gauges should be used. The conductors used to connect smoke detectors to control panels and accessory devices should be color-coded to prevent wiring mistakes. Improper connections can prevent a system from responding properly in the event of a fire.

For signal wiring, (wiring between interconnected detectors or from detectors to auxiliary devices), it is recommended that single conductor wire be no smaller than 18 gauge. The duct smoke detector terminals accommodate wire sizes up to 12 gauge.

Smoke detectors and alarm system control panels have specifications for allowable loop resistance. Consult the control panel manufacturer’s specifications for the total loop resistance allowed for the particular control panel being used before wiring the detector loop.

**[7.1] Wiring Instructions**

The D4120 and D4P120 detectors are designed for easy wiring. The housing provides a terminal strip with clamping plates. The D4S housing provides 4 wiring terminals with clamping plates. Wiring connections are made by sliding the bare end of the wire under the plate, and tightening the clamping plate screw. See **Figure 14** on page 8 for system wiring.

**[7.2] Sensor 2 Installation/Wiring**

The power board is capable of controlling a second housed sensor. The second sensor, model D4S, can be wired to the power board per the following:

1. Connect wires to the four wire terminals in the corner of the D4S sensor housing designated as Tamper (Y,Y), +R, and -B. Route wires through the conduit openings in the sensor housing and D4120 power board housing.
2. Connect the opposing ends of the wires to the terminal connections marked “Sensor 2” on the Power board. See **Figure 13** for reference. Ensure that wires are connected to the appropriate terminal locations.

**TABLE 3. Field Selectable Dip Switch Settings**

Designation	Options	Factory Default	Function
TRBL SHUTDN	OFF/ON	OFF	Shutdown on Trouble - When “ON”, auxiliary relays will switch to shutdown fans, activate dampers, etc. upon a trouble or sensor maintenance condition.
SENSORS	1/2	1	Number of Connected Sensors - When a second sensor is wired to the power board, switch must be set to “2”.
MIN TMPR DELAY	7/0	7	Cover Tamper Delay - Provides a 7 minute delay in sending a trouble condition upon cover removal while service or maintenance is being performed. If set to “0”, an instantaneous trouble condition will occur upon cover removal.

A No. 0 or 1 phillips screwdriver should be used for terminal connection. The tamper terminals are not polarity sensitive.

3. Adjust the middle dip switch on the power board to indicate (2) sensors as shown in **Figure 13**.

**[7.3] Perform Detector Check**

1. Perform STANDBY AND TROUBLE TEST per Section [8.1].
2. Perform MAGNET TEST per Section [8.1.1]. The RTS451 test in Section [8.1.2] may substitute for this requirement.
3. Perform AIR FLOW TEST per Section [8.2.1].
4. Perform SMOKE RESPONSE TEST per Section [8.2.3].

**[7.4] Field Selectable Settings**

There is a three position dip switch located in a corner of the power board for field selectable settings. See **Figure 13** for reference.

Refer to **Table 3**. Prior to installing cover, check settings for shutdown, # of sensors and tamper delay.

**[7.5] Install The Cover**

Install the covers making sure that the cover fits into the base groove. Tighten the seven screws that are captured in the covers.

**[8] Duct Smoke Detector Test & Maintenance Procedures**

Test and maintain duct detectors as recommended in NFPA 72. The tests contained in this manual were devised to assist maintenance personnel in verification of proper detector operation.

Before conducting these tests, notify the proper authorities that the smoke detection system will be temporarily out of service. Disable the zone or system under test to prevent unwanted alarms.

**[8.1] Standby, Trouble and Alarm Tests**

Refer to Table 1 on page 1 for detector status indication. The use of a remote accessory for visible indication of power and alarm is recommended.

**[8.1.1] Alarm Tests**

- 1a. Test/Reset Button - Press and hold the test button located on the power board cover for at least 2 seconds.

OR

- 1b. M02-04-00 Magnet Test - Place the painted surface of the magnet onto the MAGNET TEST location on the sensor cover of unit (**Figure 1**)
2. The red alarm LED on the sensor and the power board should latch on, as should any accessories (i.e. RA400Z, RTS451). Verify system control panel alarm status and control panel execution of all intended auxiliary functions (i.e fan shutdown, damper control, etc.).
3. The detector must be reset by the system control panel, front cover Test/Reset button, or remote accessory.
4. To reset using the Test/Reset button on the power board cover simply Press and release.

**[8.1.2] RTS451/RTS451KEY Remote Test Station**

The RTS451/RTS451KEY Remote Test Station facilitates test of the alarm capability of the duct smoke detector as indicated in the RTS451/RTS451KEY manual. The D4120 duct smoke detector can be reset by the RTS451/RTS451KEY. If a system control panel is used, the panel itself may also require testing.

To install the RTS451/RTS451KEY, connect the device as shown in **Figure 11**; wire runs must be limited to 25 ohms or less per interconnecting wire.

**[8.1.3] SSK451 Multi-Signaling Accessory**

The SSK451 Multi-Signaling accessory combines a sounder feature with a key activated test and reset function. Green, amber and red LEDs provide



a visual indication of power, trouble, and alarm respectively. An optional strobe (PS24LOW) with a smoke lens can be added to conform to the codes of certain jurisdictions.

To install the SSK451, connect the device as shown in **Figure 12**.

## [8.2] Measurement Tests

### [8.2.1] Air Flow

The D4120 is designed to operate over an extended air speed range of 100 to 4000 FPM. To verify sufficient sampling of ducted air, turn the air handler on and use a manometer to measure the differential pressure between the two sampling tubes. The differential pressure should measure at least 0.0015 inches of water and no more than 1.2 inches of water. Because most commercially available manometers cannot accurately measure very low pressure differentials, applications with less than 500 FPM of air speed may require one of the following: 1) the use of a current-sourcing pressure transmitter (Dwyer Series 607) per Section 8.2.2; or 2) the use of aerosol smoke per section 8.2.4.

### [8.2.2] Low Flow Air Flow Test using Dwyer Series 607 Differential Pressure Transmitter

Verify the air speed of the duct using an anemometer. Air speed must be at least 100 FPM. Wire the Dwyer transmitter as shown in **Figure 5**. Connect the leads of the meter to either side of the 1000Ω resistor. Allow unit to warm up for 15 seconds. With both HIGH and LOW pressure ports open to ambient air, measure and record the voltage drop across the 1000Ω resistor (measurement 1), 4.00 volts is typical. Using flexible tubing and rubber stoppers, connect the HIGH side of the transmitter to the sampling tube of the duct smoke detector housing, and the LOW side of the transmitter to the exhaust tube of the duct smoke detector housing. Measure and record the voltage drop across the 1000Ω resistor (measurement 2). Subtract the voltage recorded in measurement 1 from the voltage recorded in measurement 2. If the difference is greater than 0.15 volts, there is enough air flow through the duct smoke detector for proper operation.

**Figure 5. Procedure for verifying air flow less than 500 FPM:**

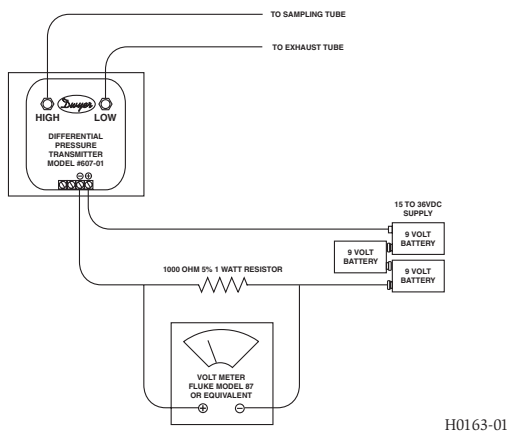

### [8.2.3] Smoke Response Tests

To determine if smoke is capable of entering the sensing chamber, visually identify any obstructions. Plug the exhaust and sampling tube holes to prevent ducted air from carrying smoke away from the detector head, then blow smoke such as cigarette, cotton wick, or punk directly at the head to cause an alarm. REMEMBER TO REMOVE THE PLUGS AFTER THIS TEST, OR THE DETECTOR WILL NOT FUNCTION PROPERLY.

### [8.2.4] Smoke Entry using Aerosol Smoke

This test is intended for low-flow systems (100-500 FPM). If the air speed is greater than 500 FPM, use a conventional manometer to measure differential pressure between the sampling tubes, as described in 8.2.1.

Drill a 1/4" hole 3 feet upstream from the duct smoke detector. With the air handler on, measure the air velocity with an anemometer. Air speed must be at least 100 FPM. Spray aerosol smoke\* into the duct through the 1/4" hole for five seconds. Wait two minutes for the duct smoke detector to alarm. If the duct smoke detector alarms, air is flowing through the detector. Remove the duct smoke detector cover and blow out the residual aerosol smoke from the chamber and reset the duct smoke detector. Use duct tape to seal the aerosol smoke entry hole.

\*Aerosol smoke can be purchased from Home Safeguard Industries, Malibu, CA. Phone: 310/457-5813.

## [8.3] Sensitivity Verification

The sensitivity of the sensor is confirmed to be operating within its allowable range each time the sensor and power board LEDs blink green every 5 seconds. Note in a maintenance condition the sensor LEDs will blink red every 5 seconds and power board will blink amber as depicted in Table 1. The maintenance condition indicates that the sensor is operating outside its original factory preset sensitivity and shall be cleaned or replaced. See Section 9 for reference. This is a valid UL test.

## [9] Detector Cleaning Procedures

Notify the proper authorities that the smoke detector system is undergoing maintenance, and that the system will temporarily be out of service. Disable the zone or system undergoing maintenance to prevent unwanted alarms and possible dispatch of the fire department.

### [9.1] Detector Sensor

1. Remove the sensor to be cleaned from the system.
2. Remove the sensor cover by pressing firmly on each of the four removal tabs that hold the cover in place. See **Figure 10** on page 6.
3. Vacuum the screen carefully without removing it. If further cleaning is required continue with Step 4, otherwise skip to Step 7.
4. Remove the chamber cover/screen assembly by pulling it straight out.
5. Use a vacuum cleaner or compressed air to remove dust and debris from the sensing chamber.
6. Reinstall the chamber cover/screen assembly by sliding the edge over the sensing chamber. Turn until it is firmly in place.
7. Replace the cover using the LEDs to align the cover and then gently pushing it until it locks into place.
8. Reinstall the detector.

### [9.2] Reinstallation

1. Reinstall the detector in its housing.
2. Restore system power.
3. Perform Detector Check, Section [7.3].
4. Notify the proper authorities testing has been completed and the smoke detector system is back in operation.

## [10] Sensor Replacement (part no. 2D51)

1. Remove the sensor head by rotating counterclockwise.
2. Pull gently to remove it.
3. To replace the sensor head, align the mounting features and rotate clockwise into place.

**Figure 6. Multiple Fan Shutdown (interconnection of D4120's):**

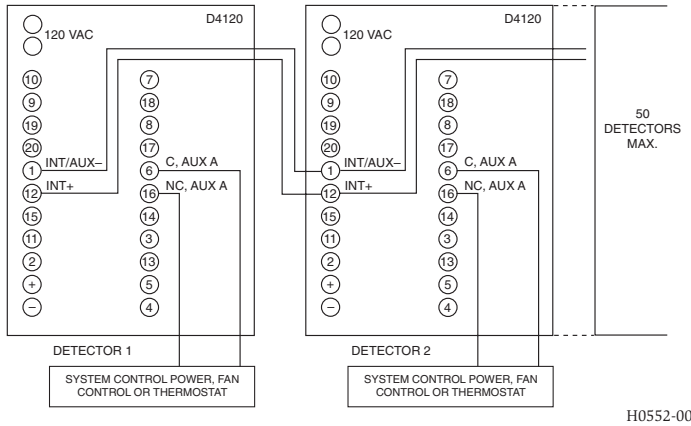

H0552-00

**Figure 7. Multiple Fan Shutdown (interconnection of D4120 to DH100ACDC):**

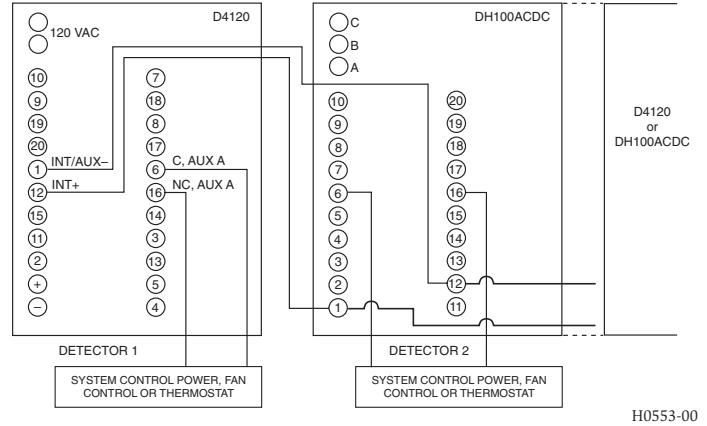

H0553-00

**Important Interconnection Notes**

- When using the interconnect feature, **all interconnected units must be powered using the same independent supply.**
- Polarity must be maintained throughout the interconnect wiring. Connect the INT + terminal on unit 1 to the INT + terminal on unit 2 and so on. Similarly, connect the INT/AUX- terminal on unit 1 to the INT/AUX- terminal on unit 2 and so on.
- Up to 50 D4120 units may be interconnected.
- Up to 10 DH100ACDC units may be interconnected. When interconnecting D4120 units with DH100ACDC units, three D4120's may be substituted for every one DH100ACDC. For example, nine DH100ACDC units may be interconnected with up to three D4120 units. A maximum of 27 D4120 units may be interconnected with one DH100ACDC.
- All interconnected detectors are to be powered from the same source.

**Figure 8. Wiring diagrams for optional accessories:**

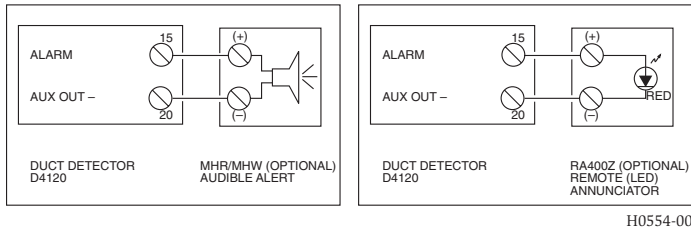

H0554-00

**Figure 9. Wiring diagram for D4120 to APA151 or APA451:**

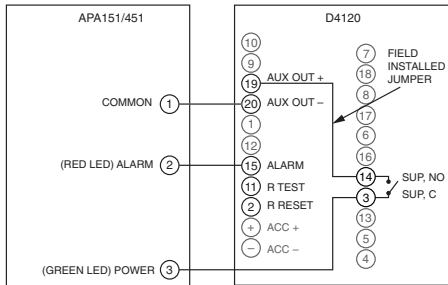

NOTE: WIRING DIAGRAM SHOWN IS FOR D4120 4-WIRE DUCT SMOKE DETECTOR SYSTEM EQUIPPED WITHOUT A CONTROL PANEL.

NOTE: A TROUBLE CONDITION IS INDICATED WHEN THE GREEN LED IS NOT ILLUMINATED.

H0584-00

**Figure 10. Detector sensor exploded view:**

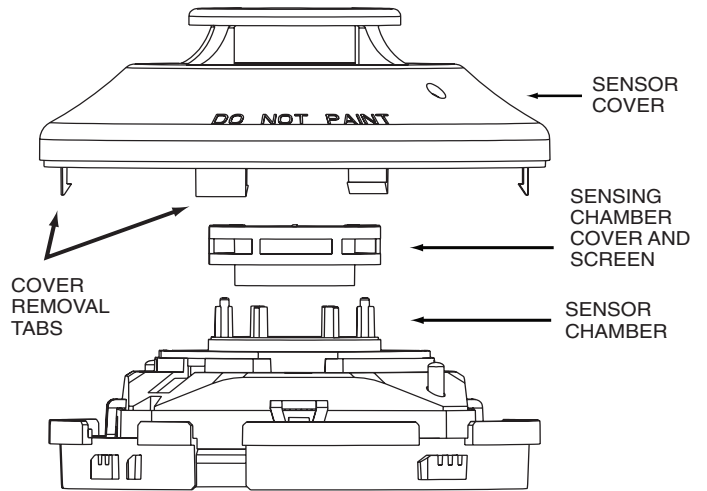

CONTACT RATING 2AMP

C1009-00

**Figure 11. Wiring diagram for D4120 to RTS451/RTS451KEY:**

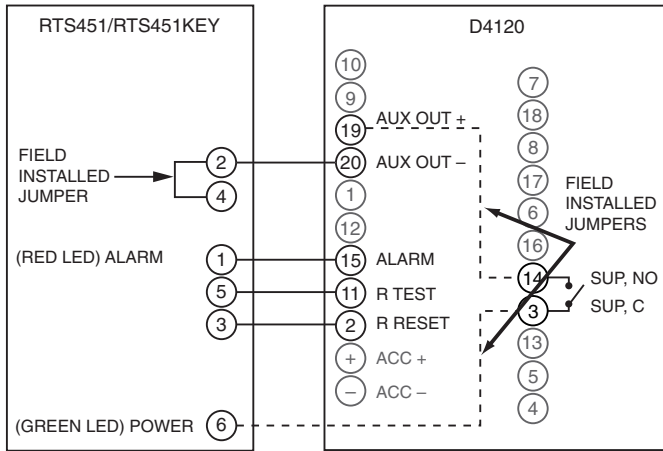

FOR RTS451KEY ONLY WITHOUT A CONTROL PANEL

H0582-00

**Figure 12. Wiring diagram for D4120 to SSK451:**

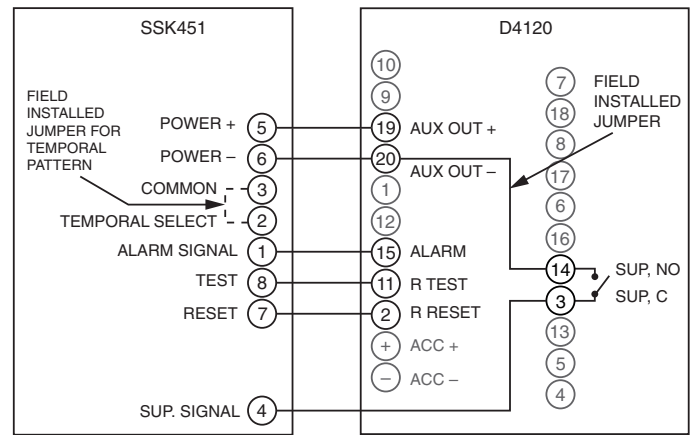

NOTE: WIRING DIAGRAM SHOWN IS FOR D4120 4-WIRE DUCT SMOKE DETECTOR SYSTEM EQUIPPED WITHOUT A CONTROL PANEL.

H0583-00

NOTE: Wiring diagram shown is for D4120 4-wire duct smoke detector system equipped without a control panel.

**Figure 13. Optional sensor 2 configuration and wiring:**

**D4S  
SENSOR ONLY**

NOTE: IF USING (2) D4S SENSOR ONLY COMPONENTS WITH MODEL D4P120 POWER BOARD COMPONENT, USE SENSOR #1 TERMINALS AND WIRE IN SAME MANNER AS SHOWN FOR SENSOR #2.

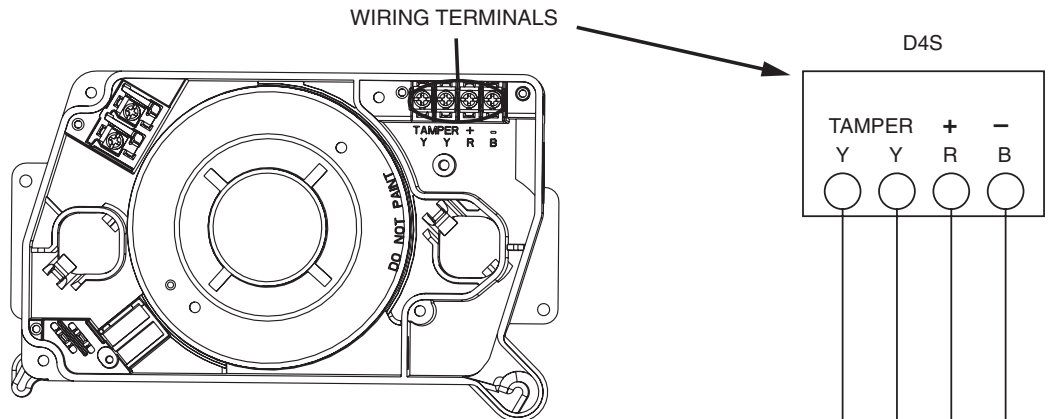

**D4120  
CO-LOCATED**

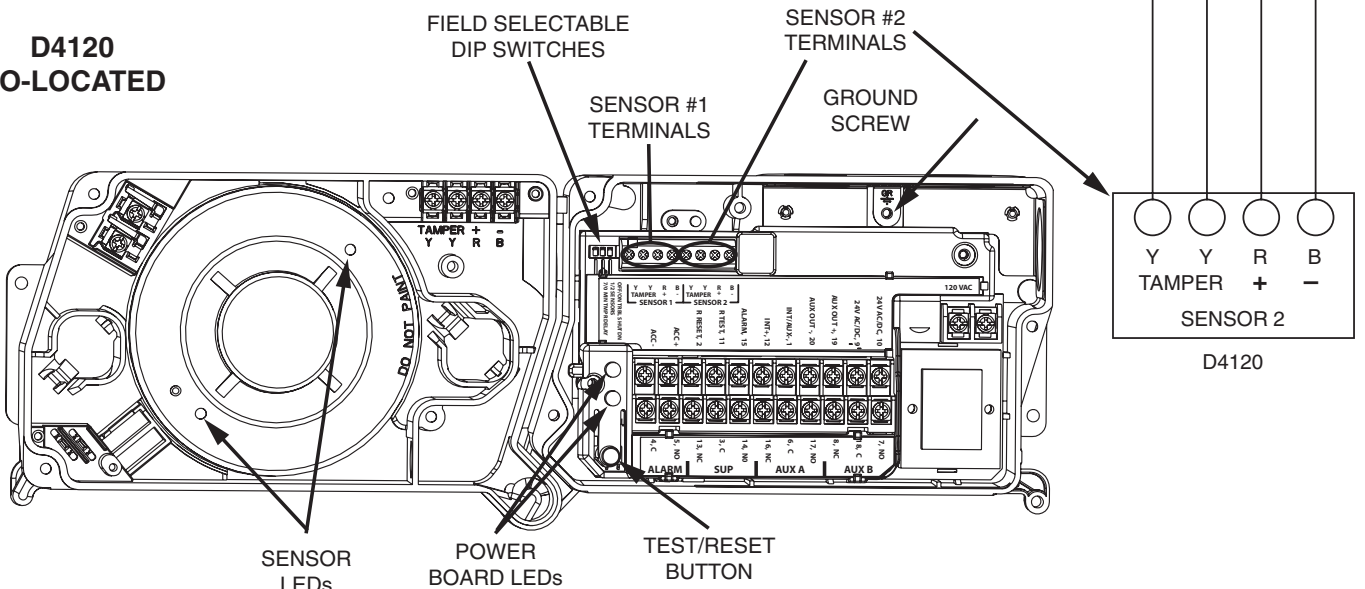

H0557-00

**Figure 14. System wiring diagram for 4-wire duct smoke detectors:**

**CAUTION**

Do not loop wire under terminals when wiring detectors. Break wire runs to provide system supervision of connections.

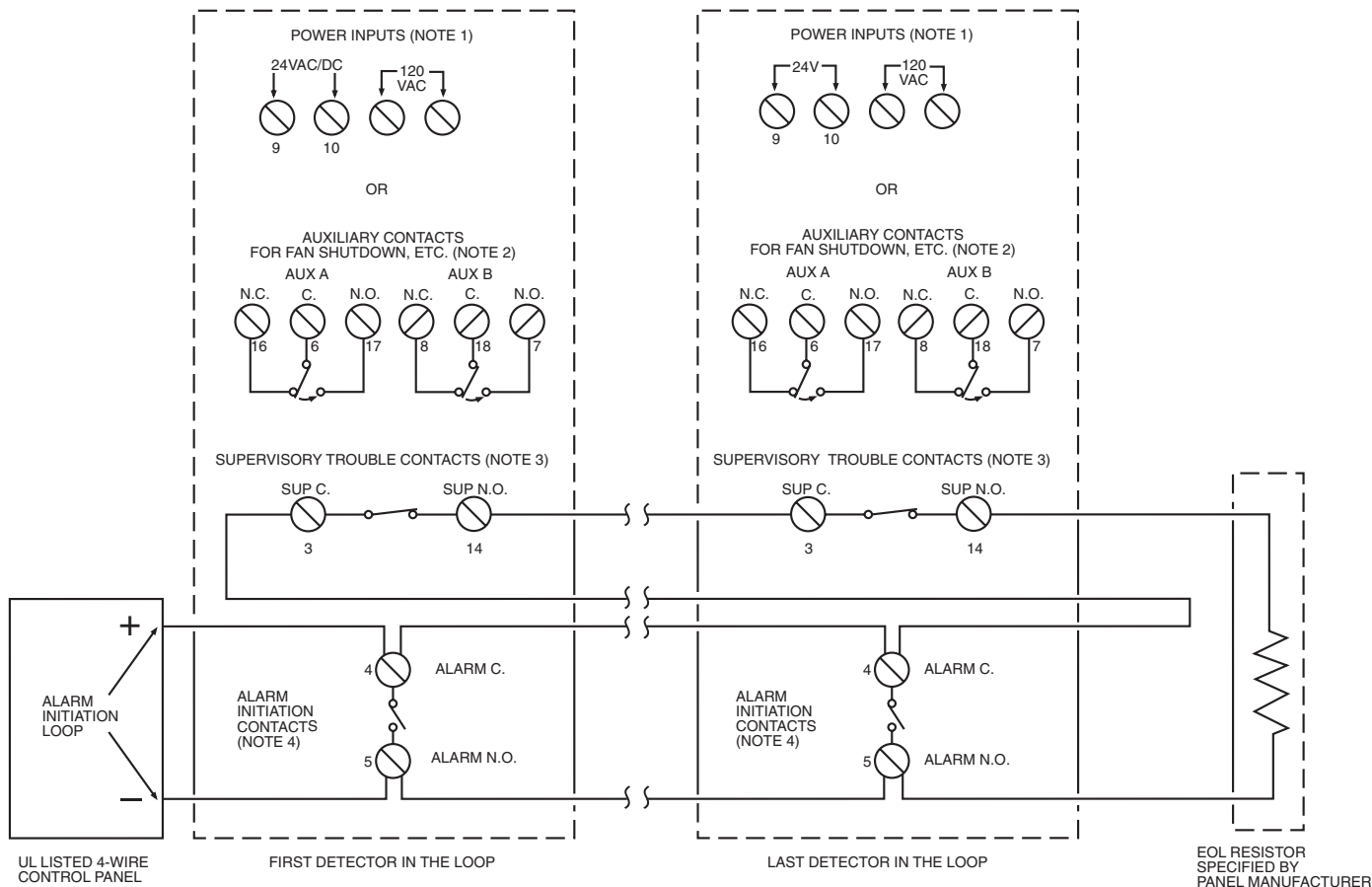

H0558-00

**NOTE 1:** 24V Power Inputs accept a non-polarized 24VDC or 24VAC 50-60Hz. 120VAC Power Inputs accept only 120VAC 50-60Hz. Connect power source to appropriate terminals of each detector. See specifications for additional power supply information.

**NOTE 2:** Auxiliary contacts shown in standby position. Contacts switch during alarm as indicated by arrows. Contacts will also switch during sensor maintenance, loss of communication with sensor, and when cover tamper times out if Shutdown on Trouble feature is selected. Auxiliary contacts are not to be used for connection to the control panel. See specifications for contact ratings.

**NOTE 3:** Trouble contacts shown in standby position. Open contacts indicate a trouble condition to the panel. Contacts open during sensor maintenance, loss of communication with sensor, loss of power, or when cover tamper feature times out. See specifications for contact ratings.

**NOTE 4:** Alarm Initiation contacts shown in standby position. Closed contacts indicate an alarm condition to the panel. Contacts close only during an alarm condition. See specifications for contact ratings.

## Please refer to insert for the Limitations of Fire Alarm Systems

### Three-Year Limited Warranty

System Sensor warrants its enclosed product to be free from defects in materials and workmanship under normal use and service for a period of three years from date of manufacture. System Sensor makes no other express warranty for the enclosed product. No agent, representative, dealer, or employee of the Company has the authority to increase or alter the obligations or limitations of this Warranty. The Company's obligation of this Warranty shall be limited to the replacement of any part of the product which is found to be defective in materials or workmanship under normal use and service during the three year period commencing with the date of manufacture. After phoning System Sensor's toll free number 800-SENSOR2 (736-7672) for a Return Authorization number, send defective units postage prepaid to: System Sensor, Returns

Department, RA # \_\_\_\_\_, 3825 Ohio Avenue, St. Charles, IL 60174. Please include a note describing the malfunction and suspected cause of failure. The Company shall not be obligated to replace units which are found to be defective because of damage, unreasonable use, modifications, or alterations occurring after the date of manufacture. In no case shall the Company be liable for any consequential or incidental damages for breach of this or any other Warranty, expressed or implied whatsoever, even if the loss or damage is caused by the Company's negligence or fault. Some states do not allow the exclusion or limitation of incidental or consequential damages, so the above limitation or exclusion may not apply to you. This Warranty gives you specific legal rights, and you may also have other rights which vary from state to state.