

Performance Selection Data

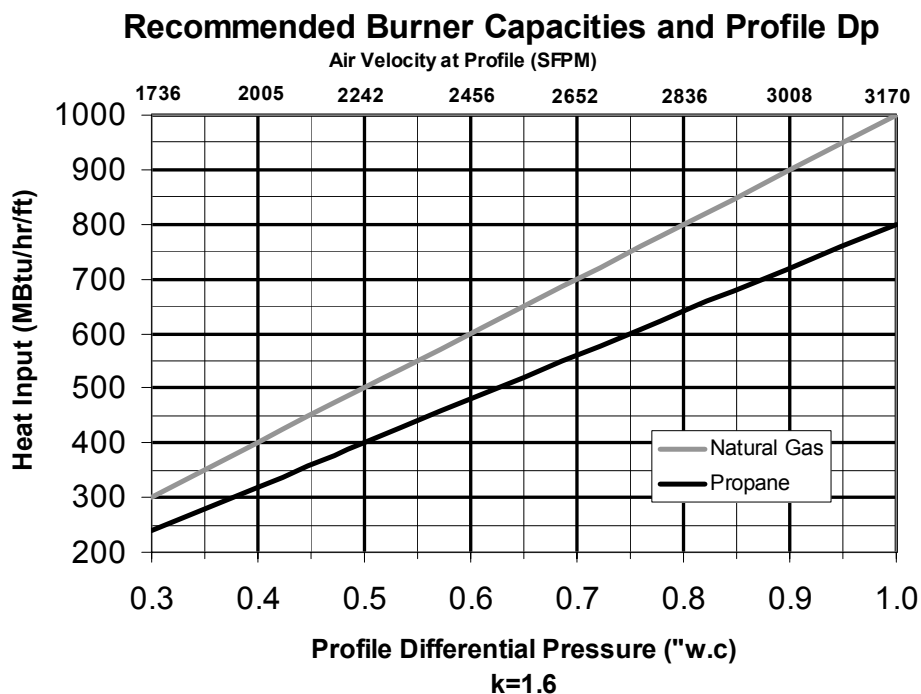

Fuel Pressure Requirements

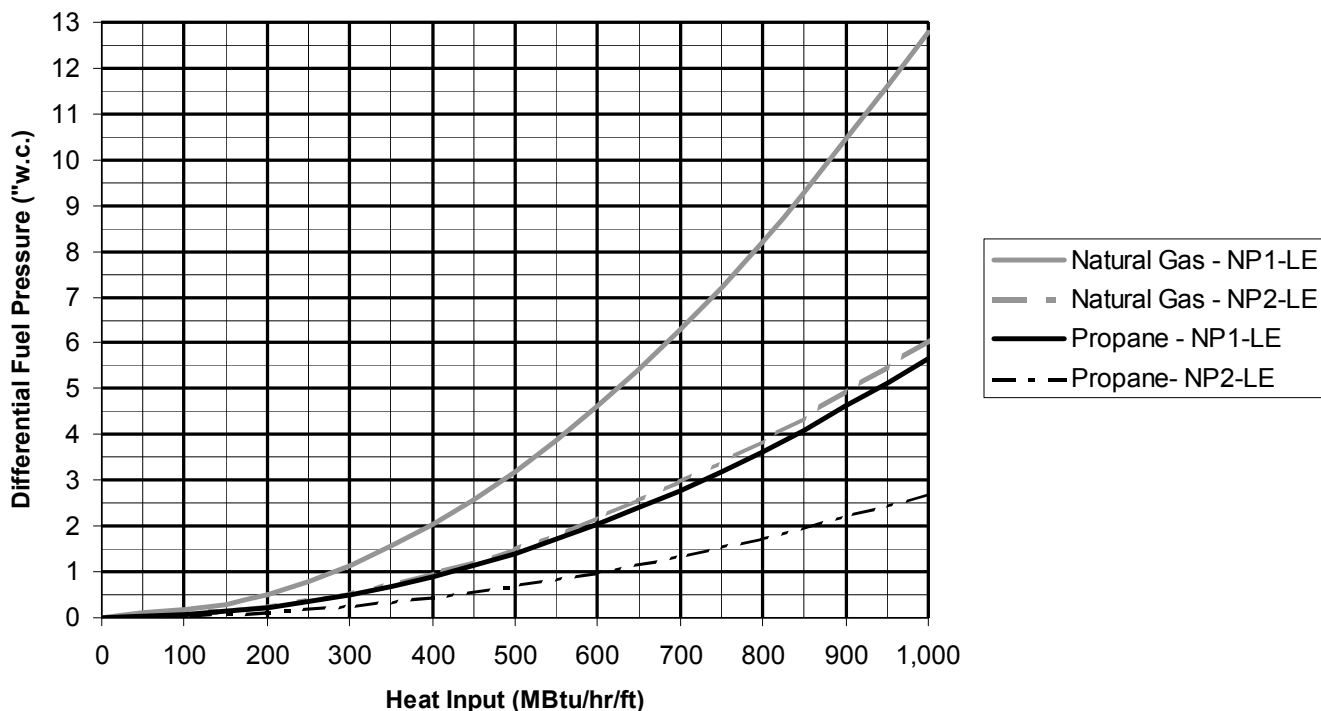

Performance Selection Data

NO_x Emissions Profile

Profile Dp 0.7"w.c.

NP1-LE

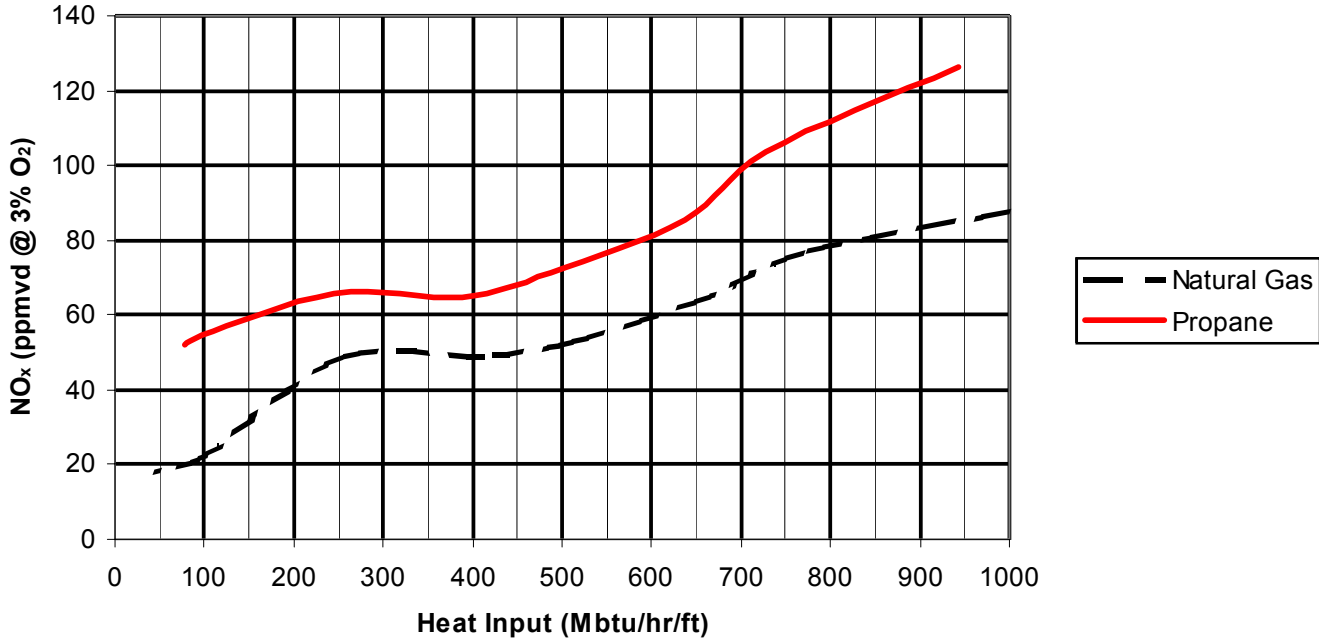

CO Emissions Profile

Profile Dp 0.7" w.c.

NP1-LE

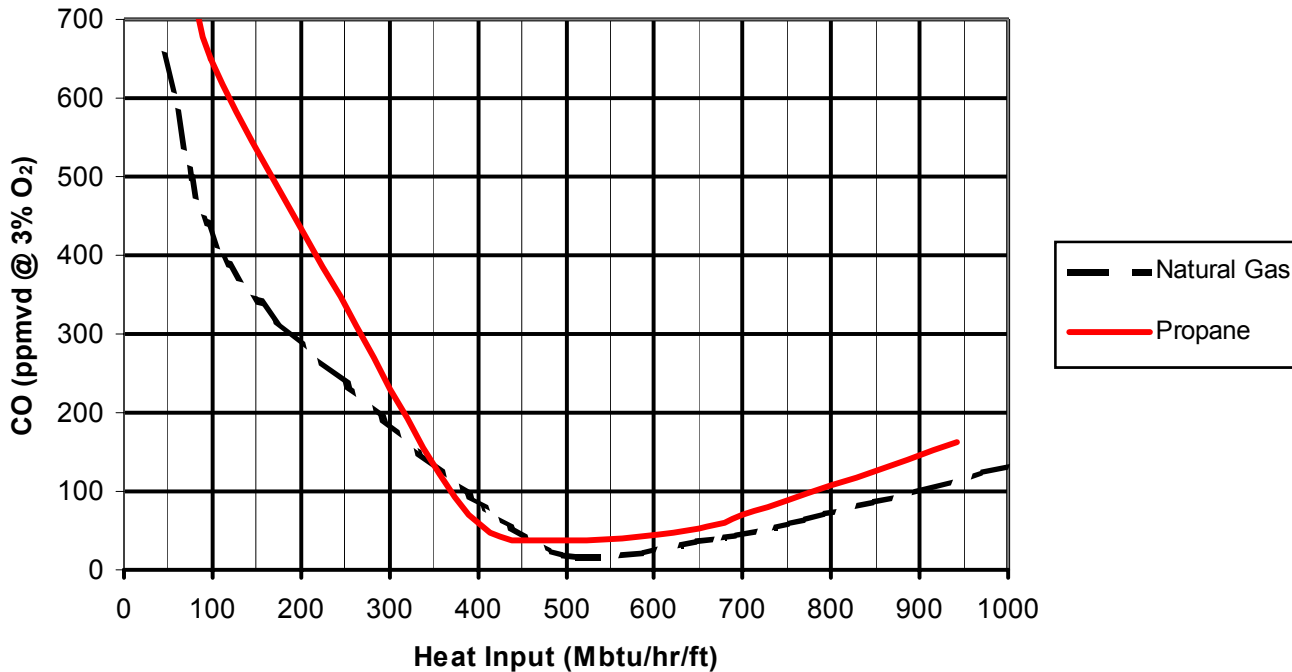

Note: Emission performance is application specific and may vary.

Performance Selection Data

NO₂ Emissions Profile

Nominal Firing Rate
NP1-LE

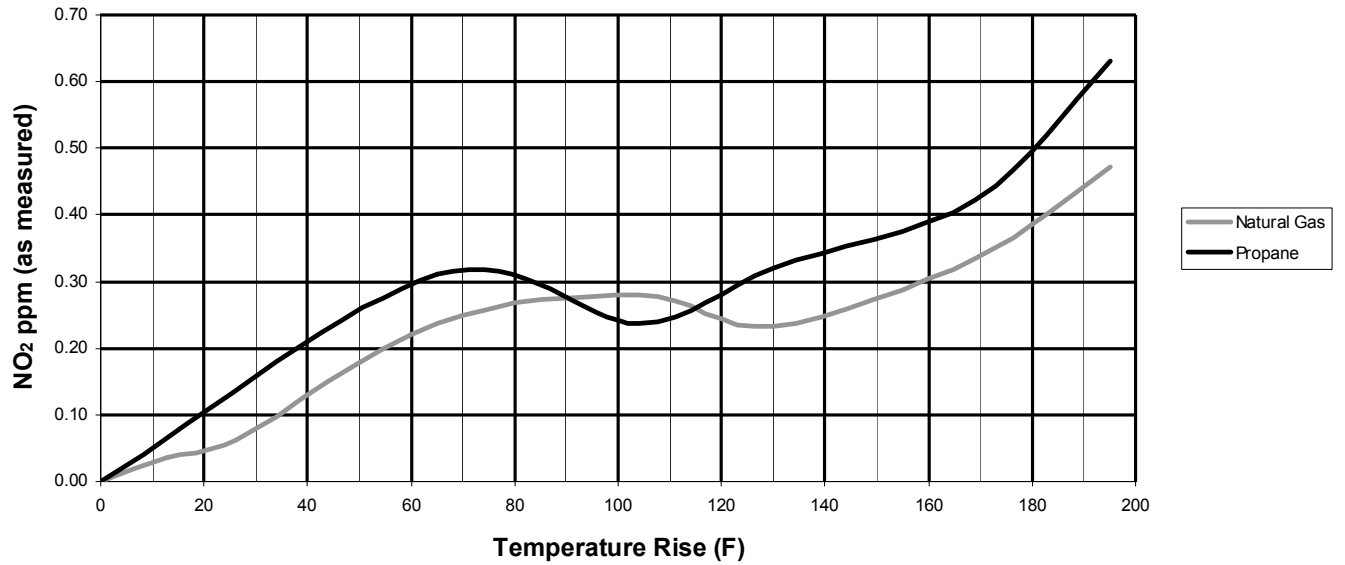

CO Emissions Profile

Nominal Operating Conditions
NP1-LE CO vs. Temperature Rise

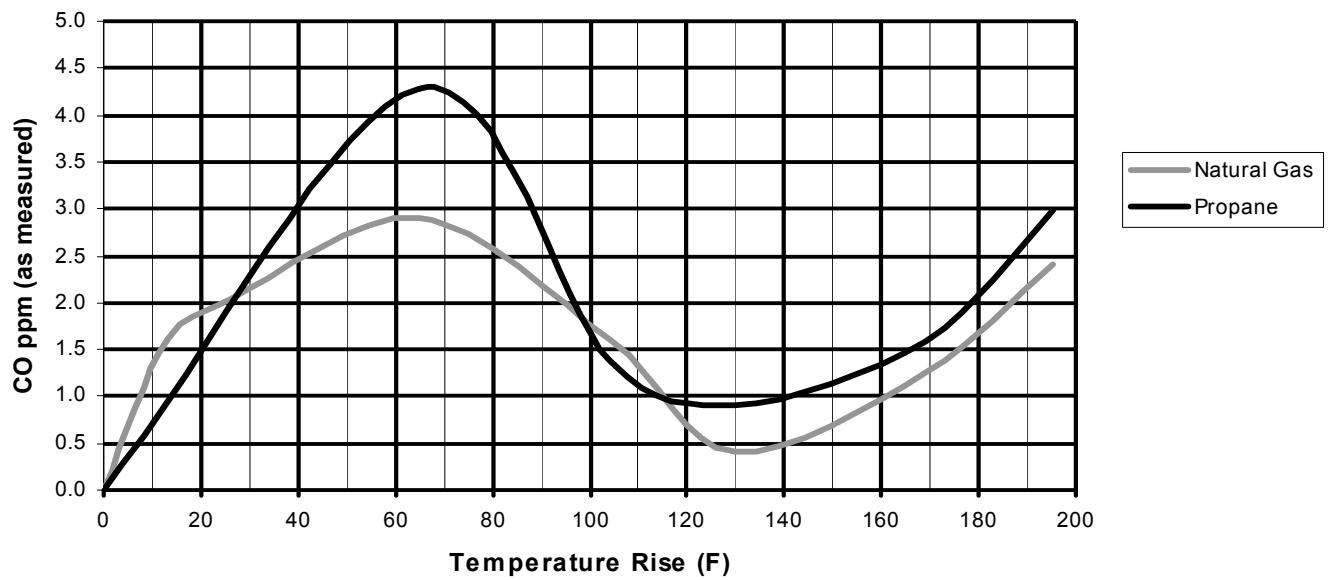

Performance Selection Data

Flame Length

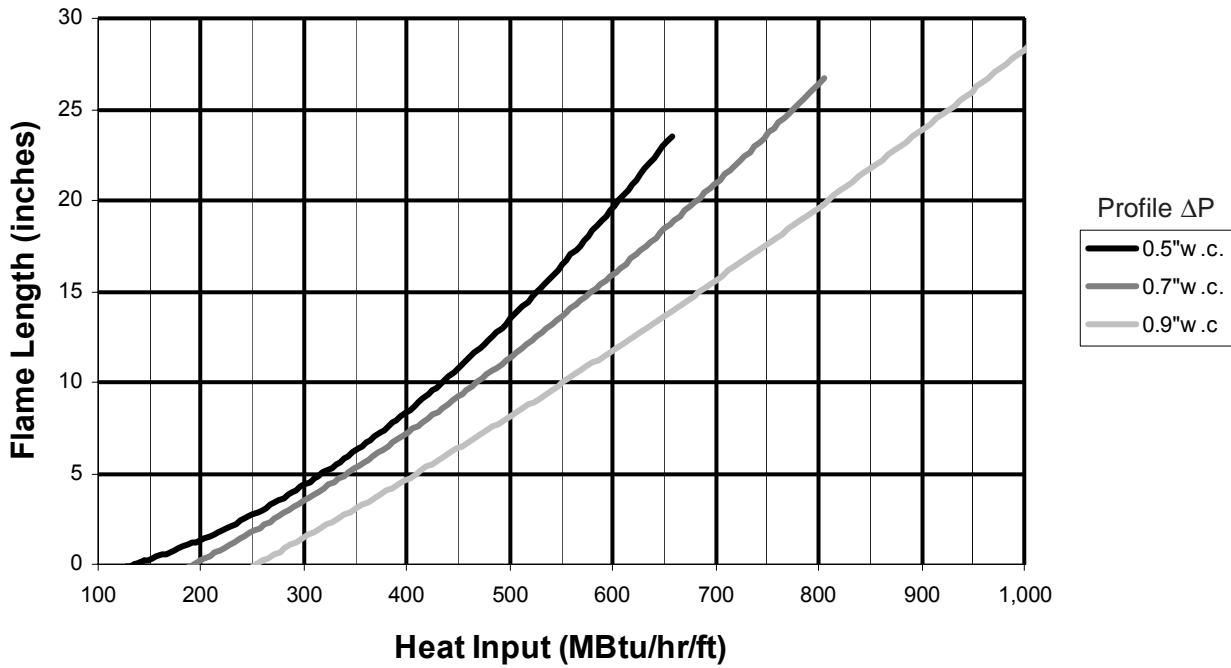

Pilot Capacities

Description	Fuel	Flow (SCFH)	Pressure ("wc)
Cast Iron End Plate with Fixed Orifice	Natural Gas	20-30	2-5
	Propane	8-12	1.4-3
LT End Plate Without Fixed Orifice	Natural Gas	10-60	0.1-2
	Propane	4-24	0.1-1.0

Note: Excessive pilot fuel flow will lead to lighting difficulties and ignitor failure.

Performance Selection Data

Airstream velocity across and through your burner's mixing plates must be kept uniform and within desired limits by use of a silhouette profile plate through which the burner fires. A 6" (minimum) profile plate should be installed surrounding the interior duct walls. See Figure 1 at right for specifications.

$$\text{Profile Design Velocity (SFPM)} = \sqrt{\left(\frac{\Delta P \times 144 \times 2 \times 32.2 \times 3600}{27.68 \times 0.075 \times 1.6} \right)}$$

Where ΔP = Profile Differential Pressure ("w.c.)

To determine profile opening areas, add burner displacement areas (ft²/section) from Table 1 (below) for your complete burner assembly to "Net Free Area" of your duct:

Net Free Area of Duct (ft²) = Fan Volume (SCFM)/Design Velocity (SFPM)

Effective Burner Displacement (ft²) = Sum of Section Areas (per Table 1) – Effective Displacement Adjustment

Effective Displacement Adjustment (ft²) = Length of mixing plate adjacent to profile plate (inches) x 1.85/144

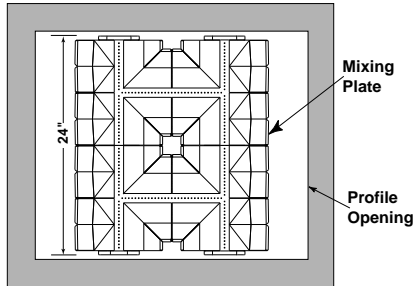

(2) 36" Back Inlet Sections

Example Calculation:

Eff. Displ. Adj. (ft²) = 2(24") x 1.85/144 = 0.6 (ft²)

Eff. Brnr. Displ. (ft²) = 2(1.8) – 0.6 = 3.0 (ft²)

$$\text{Profile Area (ft}^2\text{)} = \text{Net Free Area of Duct (ft}^2\text{)} + \text{Effective Burner Displacement (ft}^2\text{)}$$

Various duct size/profile area relationships may give slightly different field site data than is shown in Table 2. **Velocities should always be confirmed and established by use of a velometer on actual field site installation.**

Optimum design ranges for the various burner types are shown in the graphs on the preceding pages. Velocities (SFPM) are measured with a velometer directly in the duct at the plane of the profile plate or can be calculated from profile differential pressure.

$$\text{Profile Velocity Pressure (h}_v\text{)} = \frac{\rho v^2}{2g} = \frac{(0.075 \times V^2 \times 27.68)}{(2 \times 32.2 \times 144 \times 3600)}$$

Profile Differential Pressure (ΔP) = h_v x k

where V (SFPM) is velocity at profile opening.
k is resistance coef. of 1.6 for NP-LE.

Table 2: Velocity Factors (as measured with pitot tube K=1.0)

Desired velocity across burner at profile plate opening (SFPM)	1600	1800	2000	2200	2400	2600	2800	3000	3250	3500	3750	4000	4500	5000
Approximate velocity pressure reading at profile plate ("wc)	0.16	0.20	0.25	0.30	0.36	0.42	0.49	0.57	0.64	0.77	0.88	1.00	1.26	1.55
Approximate corresponding static pressure drop across profile plate ("wc)	0.26	0.32	0.40	0.48	0.58	0.67	0.78	0.91	1.02	1.23	1.41	1.60	2.02	2.48

Figure 1: Profile Plate Positioning

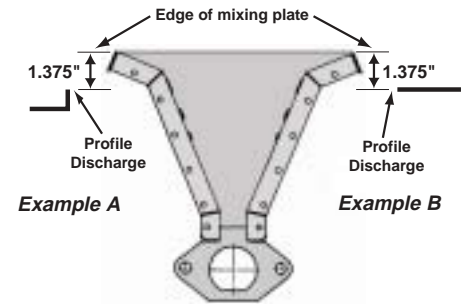

Note: Distance from end of the mixing plate to downstream edge of the profile should be 1.375"

Table 1: NP1-LE & NP-2LE Burner Displacement (ft²/section)

Section	Displacement (ft ²) *
6" Straight	0.4
12" Straight	0.8
12" Back Inlet	0.8
36" Back Inlet	1.8
12" x 6" Tee	0.9
6" x 6" Elbow	0.7

*Effective displacement is less when profiled as recommended

Table 3: Inlet Feed Limitations

Burner >	NP1-LE & NP2-LE
1-1/2" end inlet flange	equal to or less than 4 ft.
1-1/2" back inlets*	equal to or less than 5 ft.

*Note: For 36 back inlet sections, not more than 6" off any one leg

Dimensions

6" Straight

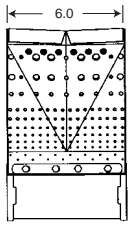

12" Straight

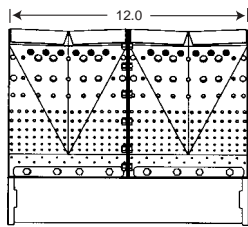

12" Back Inlet

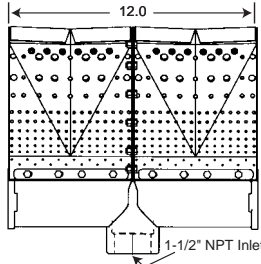

18" Straight

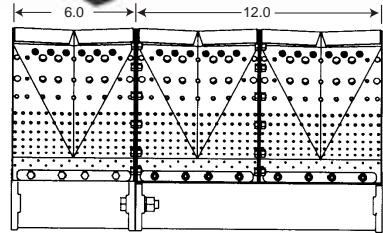

NP-LE End Profile

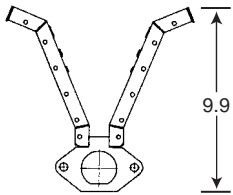

24" Straight

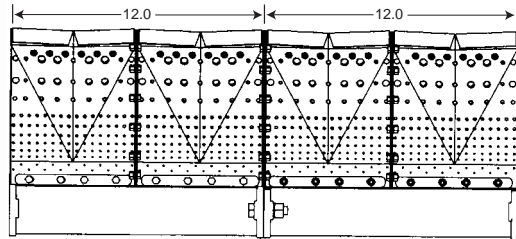
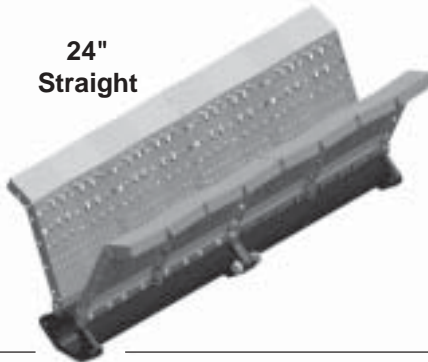

36" Back Inlet Section

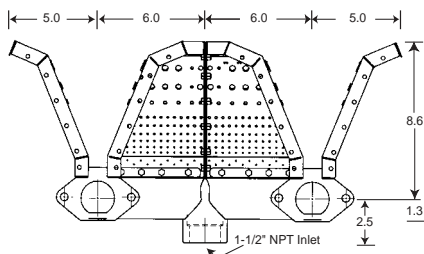
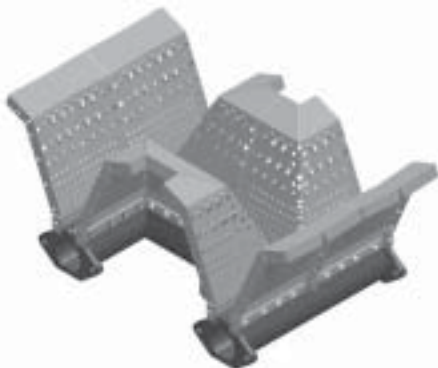

Tee Section

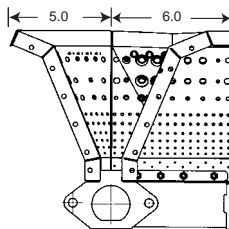

Elbow Section

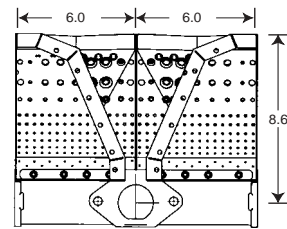
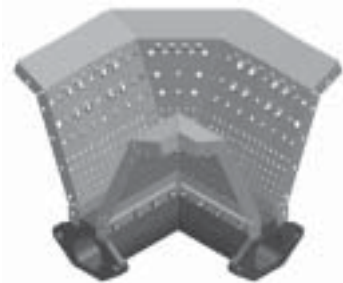

Dimensions

Plain Upper End Plate

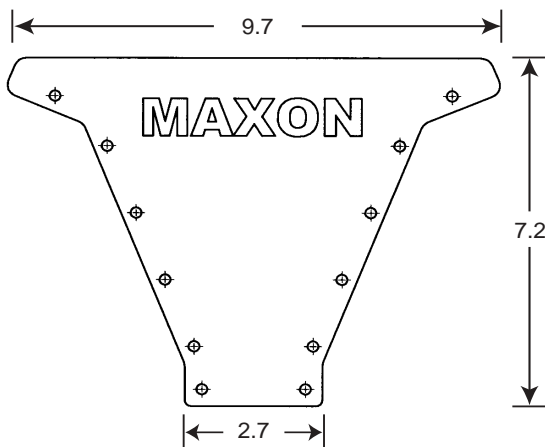

Pilot Upper End Plate

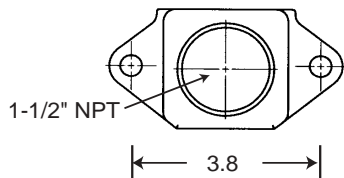
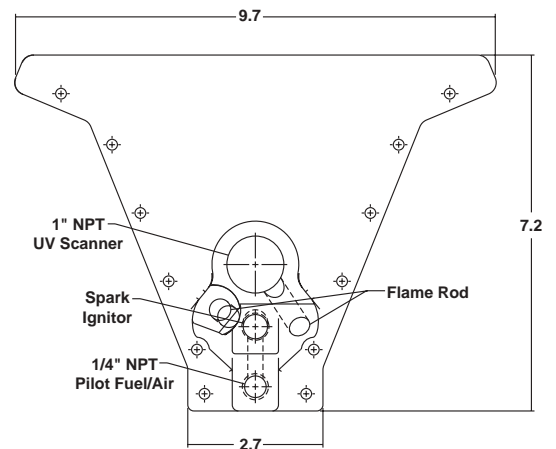

Lower Fuel Inlet End Plate

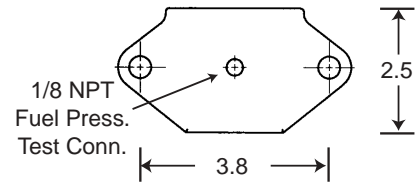

Plain Lower End Plate

Pilot 1" Angled Upper End Plate

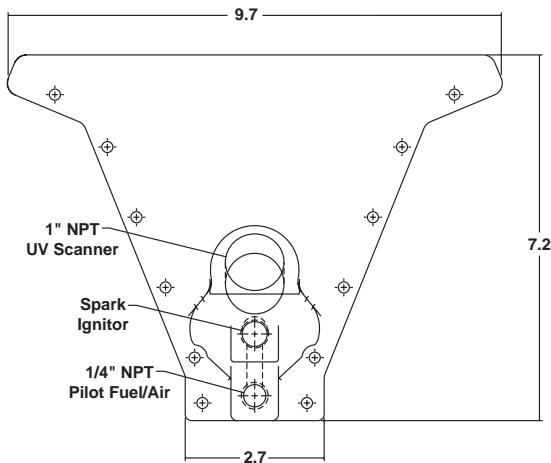

LT Pilot Upper End Plate

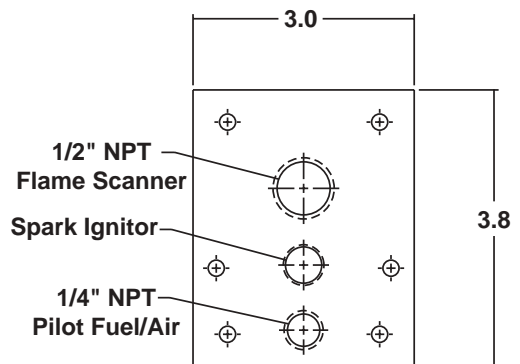

Dimensions

End Plate Assemblies



PLN



PLN FI



O/O FR PLN



O/O FR FI



LT PLN



LT PLN FI



LT PILT PLN



LT PILT FI



I/O FR PLN



I/O FR FI



1" 15DEG PLN



1" 15DEG FI

- PLN = Plain
- FI = Fuel Inlet
- O = Outwardly extending flame rod. Away from burner manifold.
- I = Inwardly extending flame rod. Toward burner manifold
- FR = Flame rod
- LT = Low temp applications
- PILT = Pilot end plate
- 1" 15DEG = UV or FR port is 1" NPT angled 15 degrees toward burner manifold

New Description	Old Description
PLN	Plain EP
PLN FI	Upper Plain/Lower Fuel
I/O FR PLN	Upper Pilot/ Lower Plain
I/O FR FI	Upper Pilot/Lower Fuel

Accessories/Replacement Items

Spark Ignitor

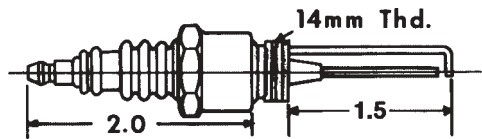

Flame Rod

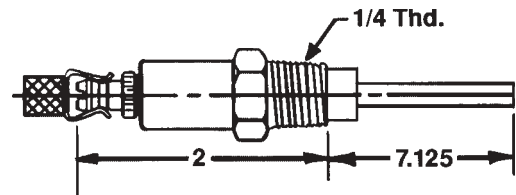

Adjustable Orifice

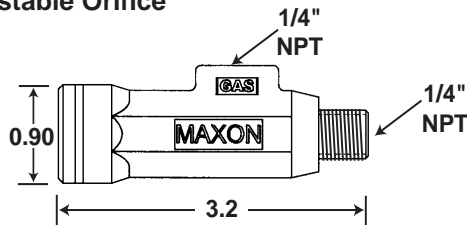

Division Plate

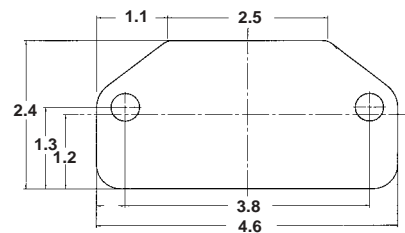

Fixed Orifice (0.100")

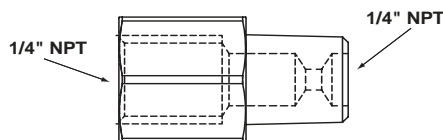

Support Brackets

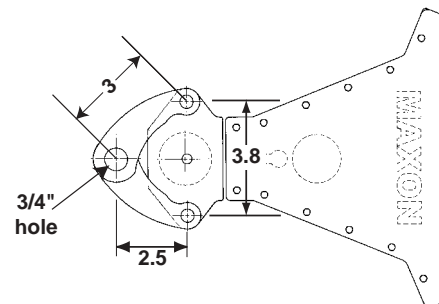

External Mounting Assembly

Frequently used to provide easy accessibility to spark ignitor and flame supervision components.



Includes Mounting Plate with two (2) feed-through insulators for internal mounting of Spark Ignitor and Flame Rod.

External Mounting Plate

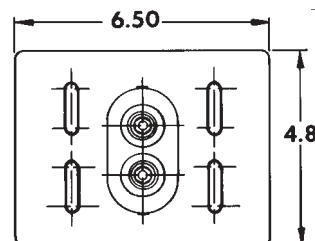

Used with typical pilot

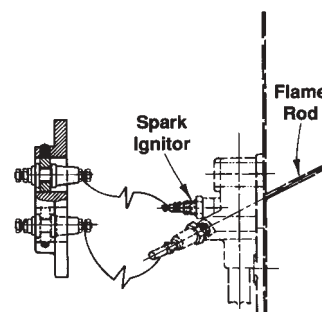

Opening Required

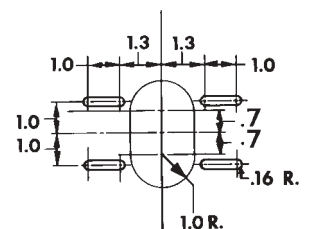

Component Identification NP-1-LE

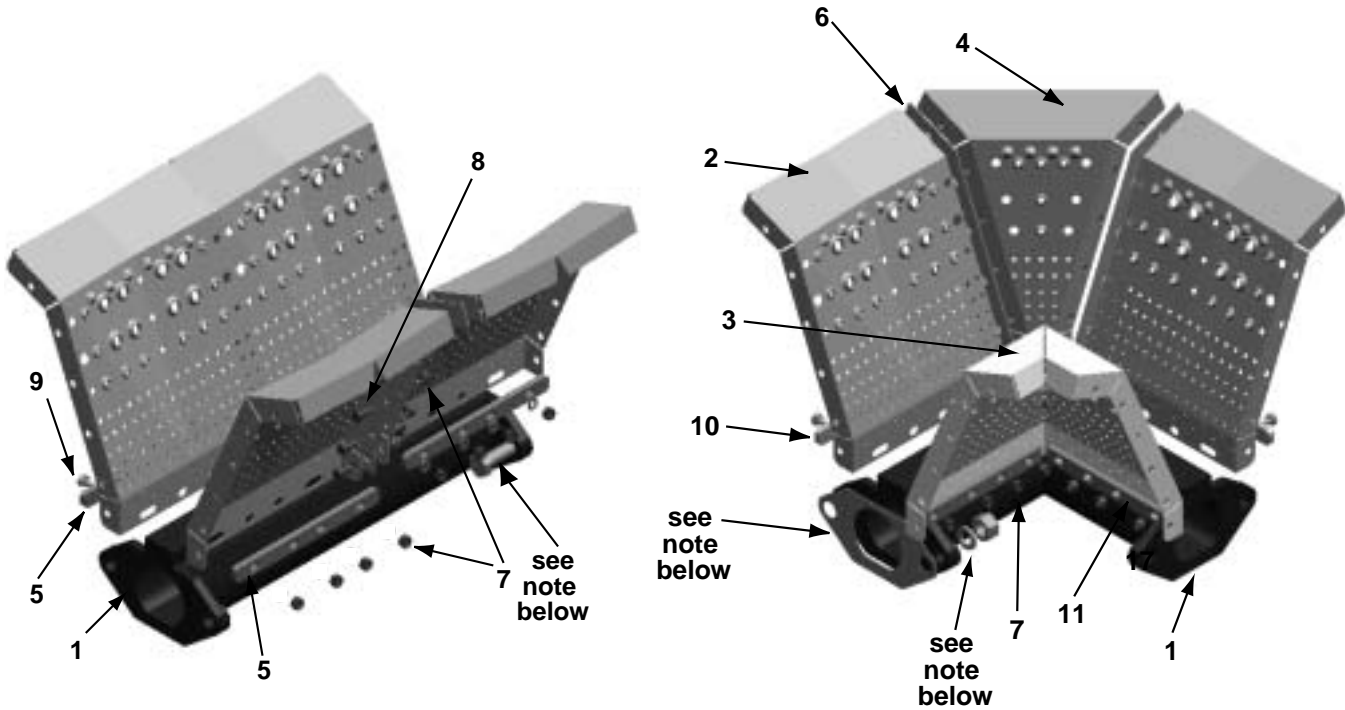

To order replacement parts:

1. See burner nameplate and indicate burner type.
2. Sketch burner arrangement (as viewed from casting side).
3. Specify replacement items required from diagrams above.
4. Specify quantity of each and assembly numbers from table below:

Item No.	Quantity Required for Indicated Section								Part Description	
	6" Str. 1050373	12" Str. 1050376	18" Str. 1050373 + 1050376	24" Str. 1050376	12" x 6" Tee 1050387	6" x 6" Elbow 1050389	12" B.I. 1050385	36" B.I. 1050390	Asby. No.	Burner Body
1										
2	2	4	6	8	2	2	4	4	1049073	Mixing Plate
3					2	1		4	1052004	Mixing Plate: Inside Corner
4						1			1049075	Mixing Plate: Wedge
5	2	4	6	8			4		18049	Back Up Bar
6		2	2	4	1	2	2	4	1049071	Gasket/Shim (Metal)
7	4	20	24	48	18	20	20	48	1051567	M5 K-Nut Plated
8		12	12	24	6	12	12	24	1051583	M5 x 10 ISO 4017 Plated Hex Bolt
9	4	8	12	16	12	8	8	24	1051570	M5 x 45 ISO 4017 Plated Hex Bolt
10					2	2		4	1050679	Outside Corner Back Up Bar
11					4	2		8	1050672	Inside Corner Back Up Bar

NOTE: These items included with fastener kits. See pages 5567 & 5568 for fastener kit details.

Component Identification NP-1-LE-AL

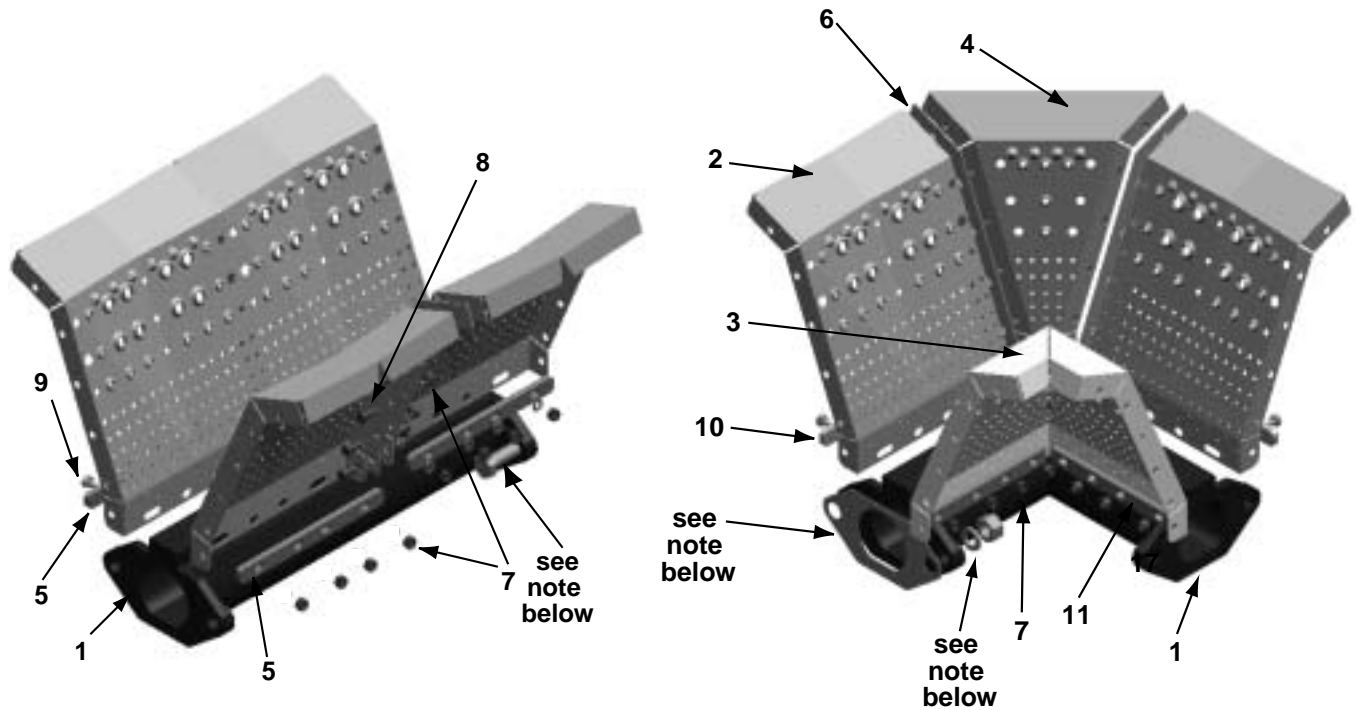

To order replacement parts:

1. See burner nameplate and indicate burner type.
2. Sketch burner arrangement (as viewed from casting side).
3. Specify replacement items required from diagrams above.
4. Specify quantity of each and assembly numbers from table below:

Item No.	Quantity Required for Indicated Section						Part Description	
	6" Str. 1050375	12" Str. 1050384	12" x 6" Tee 1050388	6" x 6" Elbow ---	12" B.I. 1050386	36" B.I. 1050391	Asby. No.	
1								Burner Body
2	2	4	2		4	4	1049073	Mixing Plate
3			2			4	1052004	Mixing Plate: Inside Corner
4							1049075	Mixing Plate: Wedge
5	2	4			4		18049	Back Up Bar
6		2	1		2	4	1049071	Gasket/Shim (Metal)
7	4	20	18		20	48	1051567	M5 K-Nut Plated
8		12	6		12	24	1051583	M5 x 10 ISO 4017 Plated Hex Bolt
9	4	8	12		8	24	1051570	M5 x 45 ISO 4017 Plated Hex Bolt
10			2			4	1050679	Outside Corner Back Up Bar
11			4			8	1050672	Inside Corner Back Up Bar

NOTE: These items included with fastener kits. See pages 5567 & 5568 for fastener kit details.

Component Identification NP-1-LE-AL-SS

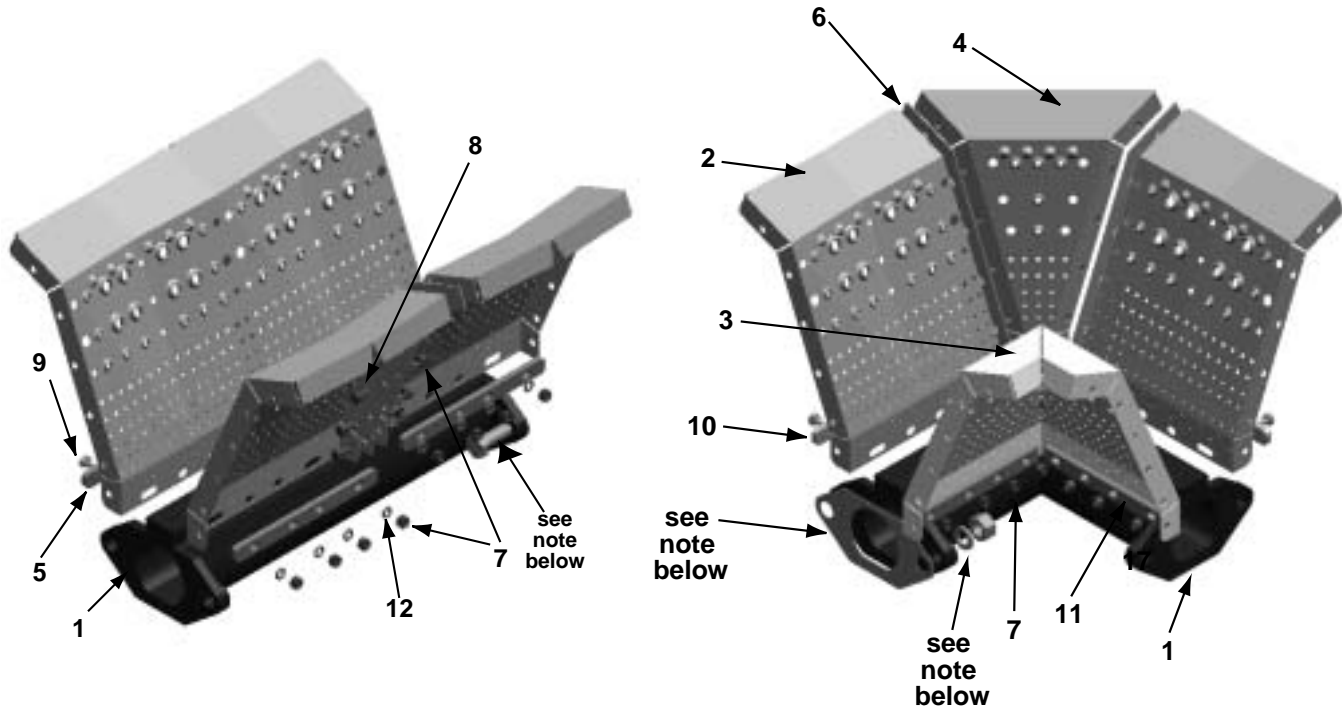

To order replacement parts:

1. See burner nameplate and indicate burner type.
2. Sketch burner arrangement (as viewed from casting side).
3. Specify replacement items required from diagrams above.
4. Specify quantity of each and assembly numbers from table below:

Item No.	Quantity Required for Indicated Section						Part Description	
	6" Str. 1050375	12" Str. 1050384	12" x 6" Tee 1050388	6" x 6" Elbow 1050389	12" B.I. 1050386	36" B.I. 1050391	Asby. No.	Burner Body
1								
2	2	4	2		4	4	1049073	Mixing Plate
3			2			4	1052004	Mixing Plate: Inside Corner
4							1049075	Mixing Plate: Wedge
5	2	4			4		45613	Back Up Bar (Aluminum)
6		2	1		2	4	1049071	Gasket/Shim (Metal)
7	4	20	18		20	48	1051566	M5 Nut Stainless Steel
8		12	6		12	24	54619	M5 x 10 ISO 4017 Hex Head Screw (Stainless Steel)
9	4	8	12		8	24	1051569	M5 x 45 Hex Head Screw Class A (Stainless Steel)
10			2			4	1050680	Outside Corner Back Up Bar (Aluminum)
11			4			8	1050673	Inside Corner Back Up Bar (Aluminum)
12	4	20	18		20	48	1051853	M5 Stainless Steel Lockwasher

NOTE: These items included with fastener kits. See pages 5567 & 5568 for fastener kit details.

Component Identification NP-2-LE

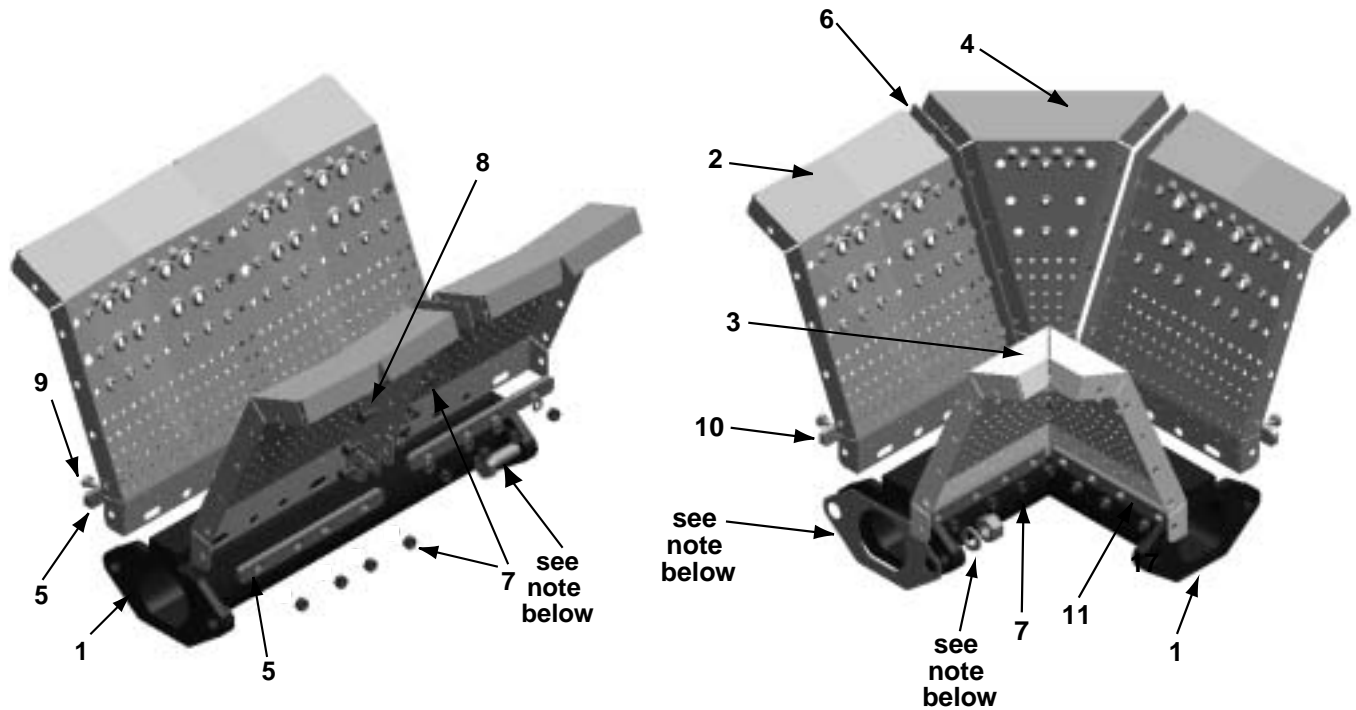

To order replacement parts:

1. See burner nameplate and indicate burner type.
2. Sketch burner arrangement (as viewed from casting side).
3. Specify replacement items required from diagrams above.
4. Specify quantity of each and assembly numbers from table below:

Item No.	Quantity Required for Indicated Section								Part Description	
	6" Str. 1051634	12" Str. 1051636	18" Str. 1051634 + 1051636	24" Str. 1051636 (qty. 2)	12" x 6" Tee 1051640	6" x 6" Elbow 1051644	12" B.I. 1051638	36" B.I. 1051642	Asby. No.	Burner Body
1										
2	2	4	6	8	2	2	4	4	1049073	Mixing Plate
3					2	1		4	1052004	Mixing Plate: Inside Corner
4						1			1049075	Mixing Plate: Wedge
5	2	4	6	8			4		18049	Back Up Bar
6		2	2	4	1	2	2	4	1049071	Gasket/Shim (Metal)
7	4	20	24	40	18	20	20	48	1051567	M5 K-Nut Plated
8		12	12	24	6	12	12	24	1051583	M5 x 10 ISO 4017 Plated Hex Bolt
9	4	8	12	16	12	8	8	24	1051570	M5 x 45 ISO 4017 Plated Hex Bolt
10					2	2		4	1050679	Outside Corner Back Up Bar
11					4	2		8	1050672	Inside Corner Back Up Bar

NOTE: These items included with fastener kits. See pages 5567 & 5568 for fastener kit details.

Component Identification Fastener Kits

Flange to Flange Fastener Kit

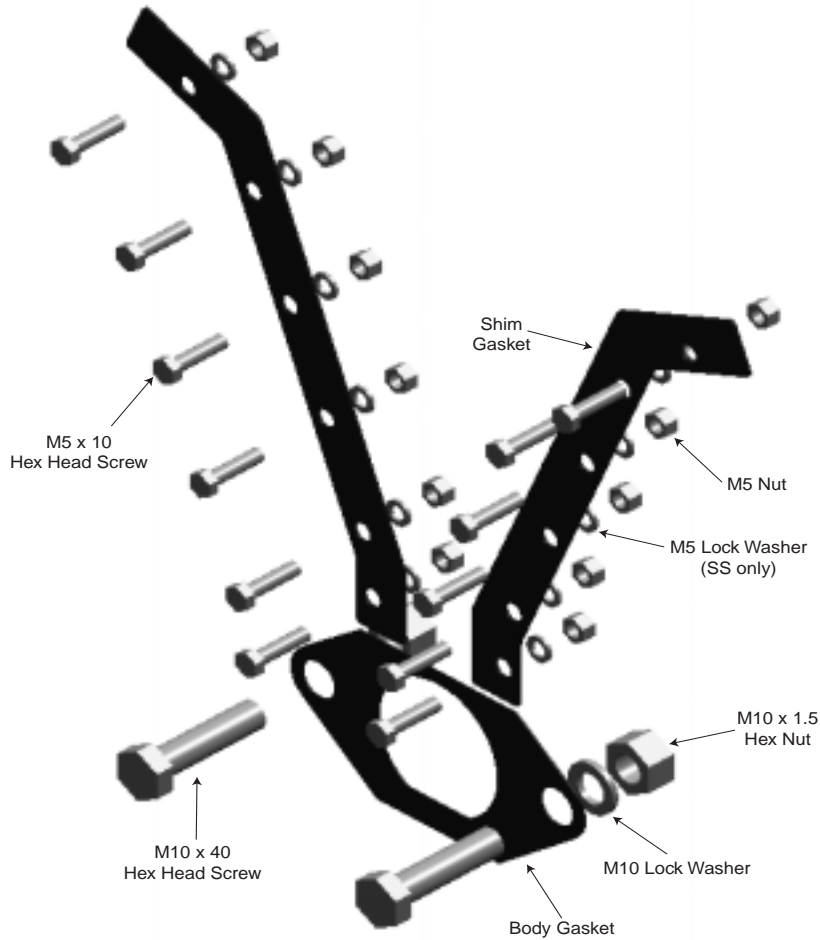

Replacement Items	Assembly Numbers			
	NP1LE	NP1LEAL	NP1LEALSS	NP2LE
Flange to Flange Fastener Kit (includes gaskets)	1051879	1051879	1051880	1051879
Body Gasket	1050424	1050424	1050424	1050424
Metal Shim Gasket	1049071	1049071	1049071	1049071

Component Identification Fastener Kits

End Plate to Flange Fastener Kit

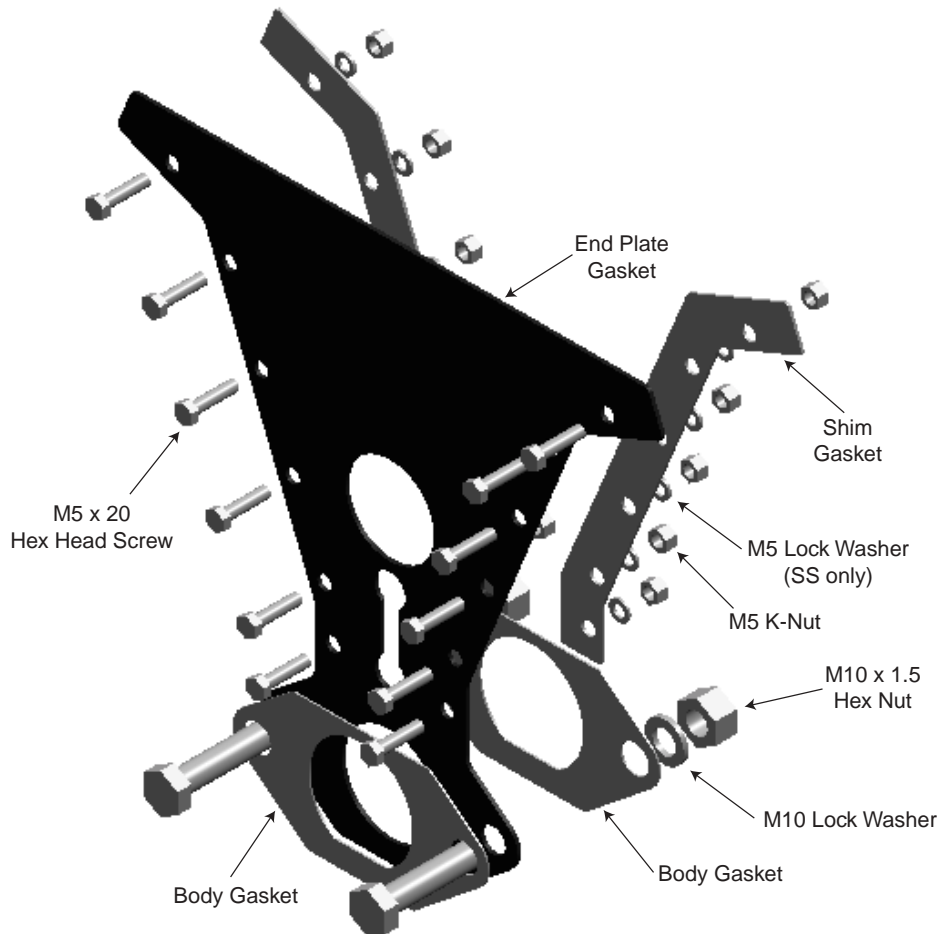

Replacement Items	Assembly Numbers			
	NP1LE	NP1LEAL	NP1LEALSS	NP2LE
End Plate to Flange Fastener Kit (includes gaskets)	1051881	1051881	1051882	1051881
Body Gasket	1050424	1050424	1050424	1050424
Metal Shim Gasket	1049071	1049071	1049071	1049071
Metal End Plate Gasket	1050423	1050423	1050423	1050423
LT Plain End Plate to Flange Fastener Kit	1057896	1057896	N/A	1057896
LT Pilot End Plate to Flange Fastener Kit	1057893	1057893	N/A	1057893
LT - Metal End Plate Gasket - Pilot	1056603	1056603	N/A	1056603
LT - Metal End Plate Gasket - Plain	1056604	1056604	N/A	1056604

Notes