



# ELECTRONIC THERMOSTAT: C1025 FOR MODULATING ELECTRIC HEAT APPLICATIONS

0 to 10 Vdc modulating output  
Vdc pulsed modulating output  
Room or supply control applications



## DESCRIPTION

The C1025 series thermostats are microcomputer-based, proportional and integral (PI) devices with one analog 0 to 10 Vdc output and one Vdc time proportioning pulsed output.

The analog 0 to 10 Vdc modulating output can control the room or supply temperature by modulating directly a 0 to 10 Vdc SCR power controller.

The Vdc pulsed output can control the room or supply temperature by modulating directly 4-32 Vdc triggered solid state relays ( SSR's ) using a time proportioning control algorithm on a 1 second time cycle.

The thermostats also contain two dip switch which adjust the following parameters :

- Room or supply control applications
- Internal or external remote sensor

## DIMENSIONS

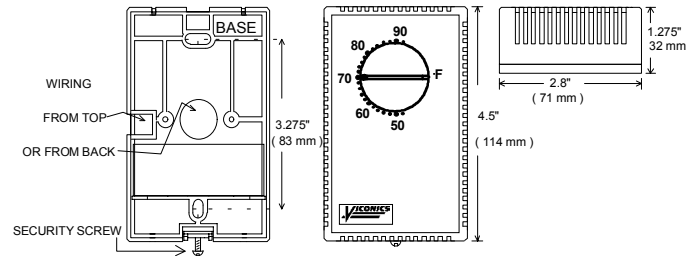

## SPECIFICATIONS

Operating Conditions: -30 °C to 50 °C ( -22 °F to 122 °F )  
0% to 95% R.H. non-condensing

Sensor: Local 47 K NTC thermistor  
Resolution:  $\pm 0.1$  °C (  $\pm 0.2$  °F )  
Control accuracy:  $\pm 0.2$  °C (  $\pm 0.4$  °F ) ( calibrated )

Ranges: C1025-02: 10 °C to 32 °C  
C1025-01: 50 °F to 90 °F

Proportional band for room temperature control ( **S1 = 0** ): 1.8°C ( 3.2°F )  
Proportional band for supply temperature control ( **S1 = 1** ): 28°C ( 50°F )

Analog 0 to 10 Vdc output: 0 to 10 Vdc into 2K $\Omega$  resistance min.  
5 mA max at 10 Vdc

Vdc pulsed output: 20 mA max at 8 Vdc.

Power: 24 Vac -15%, +10% 50/60 Hz; 2 VA

Type of output	Modulating devices for heating
Modulating analog 0 to 10 Vdc output	SCR's power controls
Vdc pulsed output	4-32 Vdc triggered SSR's

## HOW TO ORDER

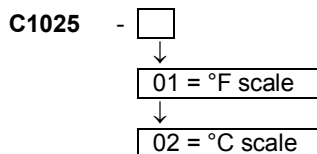

Notes: Order remote S61 sensors separately.  
Vertical covers are standard.

## ANALOG 0 TO 10 Vdc MODULATING OUTPUT

The analog 0 to 10 Vdc modulating output can control the room or supply temperature by modulating directly 0 to 10 Vdc SCR power controller.

**Use only one of the output, not both at the same time.**

## Vdc PULSED MODULATING OUTPUT

The Vdc pulsed output can control the room or supply temperature by modulating directly 4-32 Vdc triggered solid state relays ( SSR ) using a time proportioning control algorithm on a 1 second time cycle.

Ex.:

PI demand	Time on	Time off	Total cycle
50 %	½ sec.	½ sec.	1 sec.
25 %	¼ sec.	¾ sec.	1 sec.

This time proportioning output **cannot be used** on regular mechanical relays or contactors.

**Use only one of the output, not both at the same time**

## REMOTE SENSOR

A remote sensor can be wired and used with the C1025 thermostat. To wire a remote sensor, first set dip switch S2 to position 0 ( off ).

If the application is for discharge air or supply temperature control, set dip switch S1 to position 1 ( on ). This will enable a larger proportional band, making the controlled temperature more stable.

Characteristics of remote sensor 47 KΩ ( S61 ).

Temperature °F	Temperature °C	Sensor resistance
150.0 °F	65.6 °C	9.610 Kohm
140.0 °F	60.0 °C	11.700 Kohm
130.0 °F	54.4 °C	14.342 Kohm
120.0 °F	48.9 °C	17.682 Kohm
110.0 °F	43.3 °C	21.940 Kohm
100.0 °F	37.8 °C	27.412 Kohm
90.0 °F	32.2 °C	34.483 Kohm
80.0 °F	26.7 °C	43.704 Kohm
70.0 °F	21.1 °C	55.834 Kohm
60.0 °F	15.6 °C	71.866 Kohm
50.0 °F	10.0 °C	93.340 Kohm
40.0 °F	4.4 °C	122.298 Kohm

## THERMOSTAT INSTALLATION

### Important.

**Electronic controllers require special care for wiring and startup. To avoid problems, carefully follow the procedures below.**

Be sure to have all the literature on hand for all components installed: controller, actuators, relay, etc...

Look at the wiring diagrams, and study them carefully. Be sure that you understand how the system is supposed to work.

Make the wiring according to the wiring diagrams. Respect polarity for power terminals # 3 & # 4 between multiple controllers if the same transformer is used.

- Remove security screw on left side of thermostat cover.
- Open up by pulling on the bottom side of thermostat.

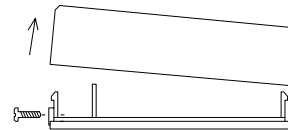

### A) Location:

- 1- Shouldn't be installed on outside wall.
- 2- Must be installed away from any heat source.
- 3- Shouldn't be affected by direct sun radiation.
- 4- Nothing must restrain vertical air circulation to the thermostat.

### B) Installation:

- 1- Pull out cables 6" out of the wall.
- 2- Wall surface must be flat and clean.
- 3- Separate the thermostat and the base by pulling the cover by the bottom (same as the security screw.)
- 4- Insert cable in the central hole of the base.
- 5- Align the base and mark the location of the two mounting holes on the wall. Install proper side of base up.
- 6- Install shields in the wall.
- 7- Insert screws in mounting holes on each side of the base. **DO NOT OVERTIGHTEN!**
- 8- Strip each wire 1/4 inch.
- 9- Insert each wire according to wiring diagram.
- 10- Reinstall the cover ( top side first ) and gently push back extra wire length in the hole in the wall.
- 11- Install security screw.

## DIP SWITCH ADJUSTMENTS PER APPLICATIONS

S1	APPLICATION SWITCH
0	For regular room control applications Proportional band is 1.8°C ( 3.2°F )
1	For discharge air or supply temperature control Proportional band is 28°C ( 50°F )

S3 switch is not used.

S2	MAIN TEMPERATURE SENSOR
0	Main temperature sensor is remote mounted
1	Thermostat internal sensor for room temperature sensing

## CONTROL CURVE AND SEQUENCE

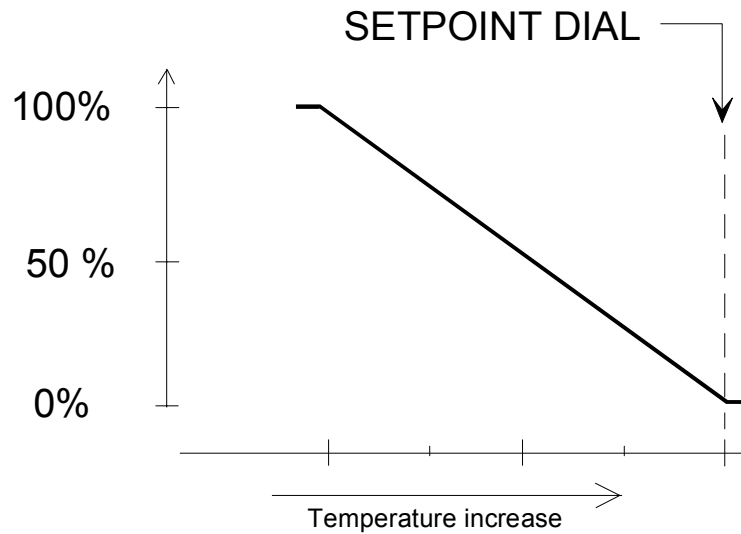

## TYPICAL APPLICATIONS

### Room Temperature Control With: 4-32 Vdc SSR's

Dip switch position	S1	S2
Heating application	0	1

The output is rated at 20 mA max at 8 Vdc.

Modulating Electric Duct Heater  
c/w 4-32 Vdc Triggered SSR

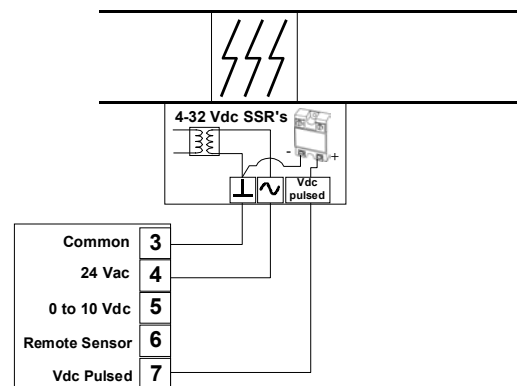
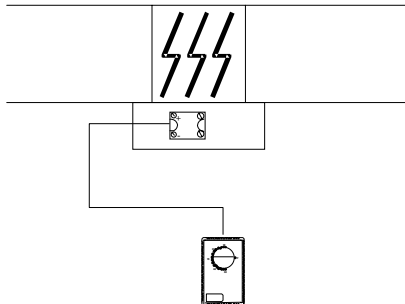

## Room Temperature Control With: 0 to 10 Vdc SCR Power Controller

Dip switch position	S1	S2
Heating application	0	1

### Modulating Electric Duct Heater 0 to 10 Vdc SCR Power Controller

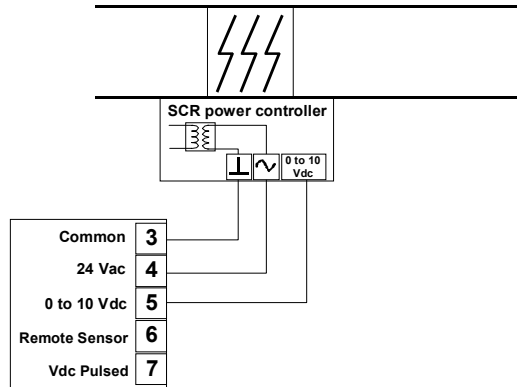
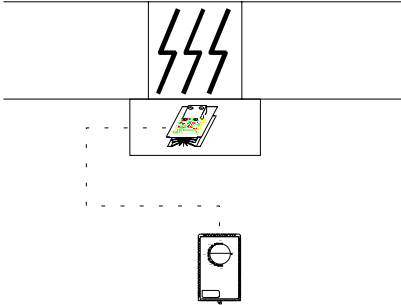

## Supply Temperature Control With: Remote Sensor & 4-32 Vdc SSR's

Dip switch position	S1	S2
Heating application	1	0

### Modulating Electric Duct Heater c/w 4-32 Vdc Triggered SSR

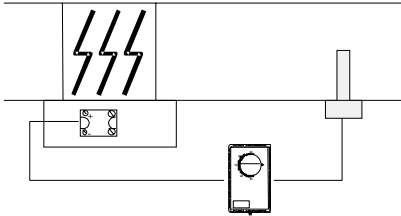

The output is rated at 20 mA max at 8 Vdc.

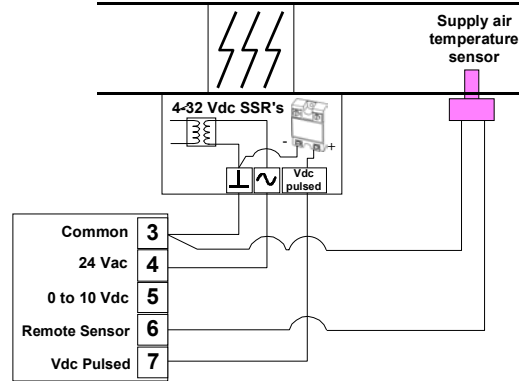

## Supply Temperature Control With: Remote sensor & 0 to 10 Vdc SCR Power Controller

Dip switch position	S1	S2
Heating application	1	0

### Modulating Electric Duct Heater 0 to 10 Vdc SCR Power Controller

