

SPECIFICATIONS

S E R I E S 1 0 0 0 AIR-FOIL CONTROL DAMPER

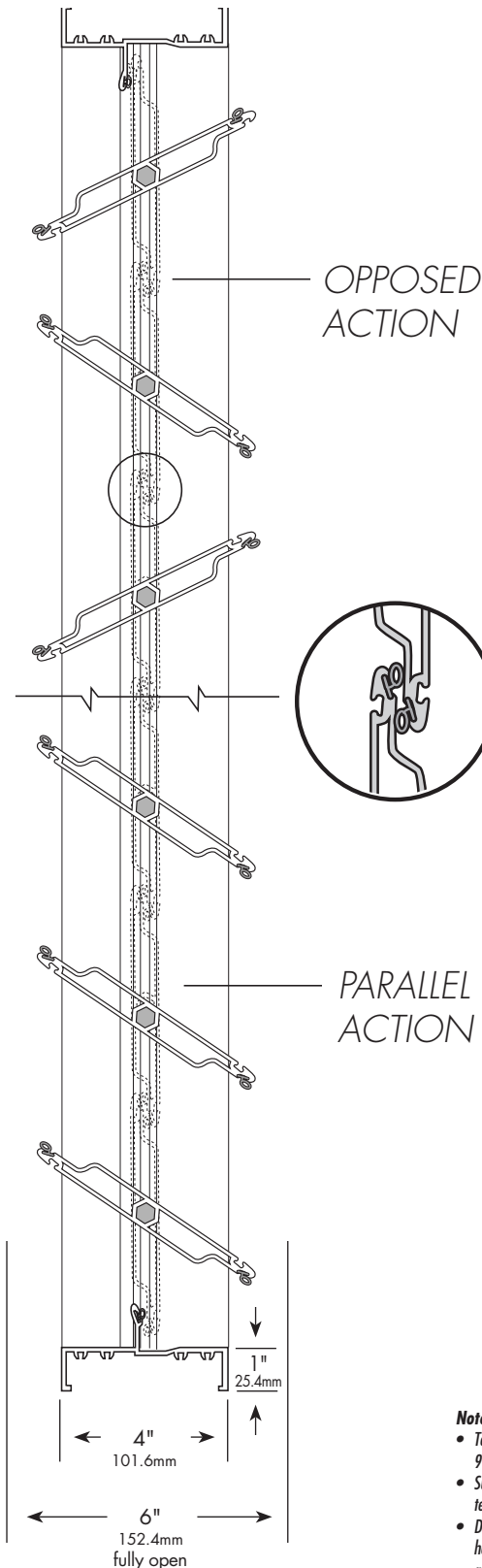

- Extruded aluminum (6063T5) damper frame is not less than .080" (2.03mm) in thickness. Damper frame is 4" deep.
- Blades are extruded aluminum (6063T5) profiles.
- Blade seals are extruded EPDM. Frame seals are extruded TPE thermoplastic. Seals are secured in an integral slot within the aluminum extrusions.
- Bearings are composed of a Celcon inner bearing fixed to a 7/16" (11.11mm) aluminum hexagon blade pin, rotating within a polycarbonate outer bearing inserted in the frame, resulting in no metal-to-metal or metal-to-plastic contact.
- Linkage hardware is installed in the frame side and constructed of aluminum and corrosion-resistant, zinc-plated steel, complete with cup-point trunnion screws for a slip-proof grip.
- Dampers are designed for operation in temperatures ranging between -40°F (-40°C) and 212°F (100°C).
- Dampers are available with either opposed blade action or parallel blade action.
- Dampers are made to size required without blanking off free area.
- Dampers are available in two mounting types: i.e., "Installed in Duct" or "Flanged to Duct".
- Installation of dampers must be in accordance with current manufacturer's installation guidelines provided with each shipment of TAMCO dampers. (Note all technical information available on TAMCO's web site at www.tamco.ca supersedes and takes precedence over all information contained within the printed catalog.)
- Intermediate or tubular steel structural support is required to resist applied pressure loads for dampers that consist of two or more sections in both height and width. (See TAMCO Aluminum Damper Installation Guidelines.)

"FLANGED TO DUCT" TYPE 2" added to duct width & height dimensions

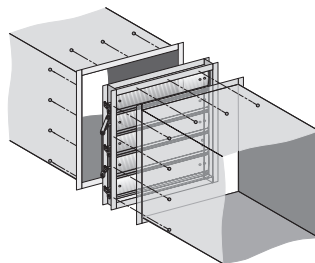

"INSTALLED IN DUCT" TYPE 1/2" deducted for clearance from width & height dimensions unless otherwise specified

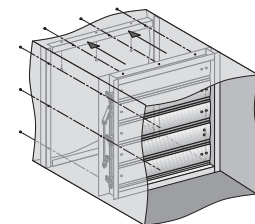

Note:

- To reduce pressure drop, use "Flanged to Duct" type for sizes under 9 ft.² (1.83m²).
- Suitable for operation in breathable air environments within stated temperature range.
- Dampers sized for duct openings exceeding 37 1/2" (953mm) in height are equipped with a stiffener bar at mid-height to strengthen and maintain air leakage tolerances.
- For open blade clearance in tight spaces, consider the Series 1400 - 4" wide air-foil blade option.

For additional information, refer to:

- Series 1000 Product Brochure
- Series 1000 Pressure Drop
- Aluminum Standard Configurations
- Series 1000 Damper Free Area Charts
- TAMCO Aluminum Damper Torque Requirements
- Multiple-Section Horizontal Jackshafts
- Configurations Using Vertical Jackshafts
- Multiple-Section Damper Jumpers
- Square-to-Round Transition Option
- Installation Guidelines For Tamco Dampers
- Series 1400 - 4" Wide Air-Foil Blade Control Damper Specification Sheet
- Series 1400 - 4" Wide Air-Foil Blade Control Damper Free Area Charts

PERFORMANCE DATA

S E R I E S 1 0 0 0 AIR-FOIL CONTROL DAMPER

LEAKAGE RATING

Damper Width (Inches)	1 In. W.G.	4 In. W.G.	8 In. W.G.
12" (305 mm)	1A	1	11
24" (610 mm)	1A	1	11
36" (914 mm)	1A	1	n/a
48" (1219 mm)	1A	1	n/a
60" (1524 mm)	1A	1	n/a

Leakage testing was conducted in accordance with AMCA Standard 500-D-98. Holding torque applied was 5.2 in.-lbs./sq. ft. on opposed blade dampers and 7 in.-lbs./sq. ft. on parallel blade dampers. AMCA Standard 500-D-98 states that air leakage is based on operation between 50°F (10°C) and 104°F (40°C). All tests were performed with 120 lb-in resulting in a maximum of 120 lb-in/ft² with the 12" x 12" damper.

The following sizes of TAMCO Series 1000 dampers were tested:

12" x 12" (305 mm x 305 mm), 24" x 24" (610 mm x 610 mm), 48" x 12" (1219 mm x 305 mm), 12" x 48" (305 mm x 1219 mm), 36" x 36" (914 mm x 914 mm), 60" x 36" (1524 mm x 914 mm).

Pressure Class	LEAKAGE, l/s/m ² (ft ² /min/ft ²)			
	Required Rating		Extended Ranges (Opt.)	
	1" / 0.25 kpa	4" / 1.0 kpa	8" / 2.0 kpa	12" / 3.0 kpa
1A	3 / 15.2	n/a	n/a	n/a
1	4 / 20.3	8 / 40.6	11 / 55.9	14 / 71.1
2	10 / 50.8	20 / 102	28 / 142	35 / 178
3	40 / 203	80 / 406	112 / 569	140 / 711

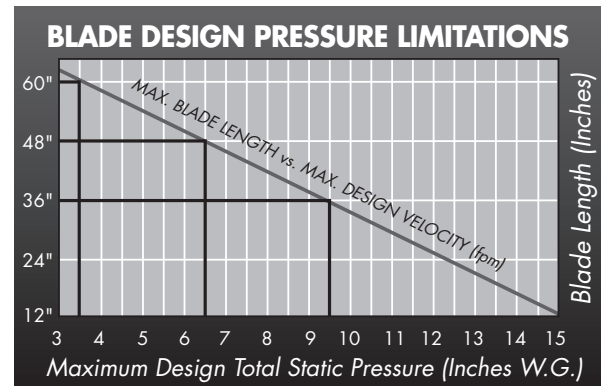
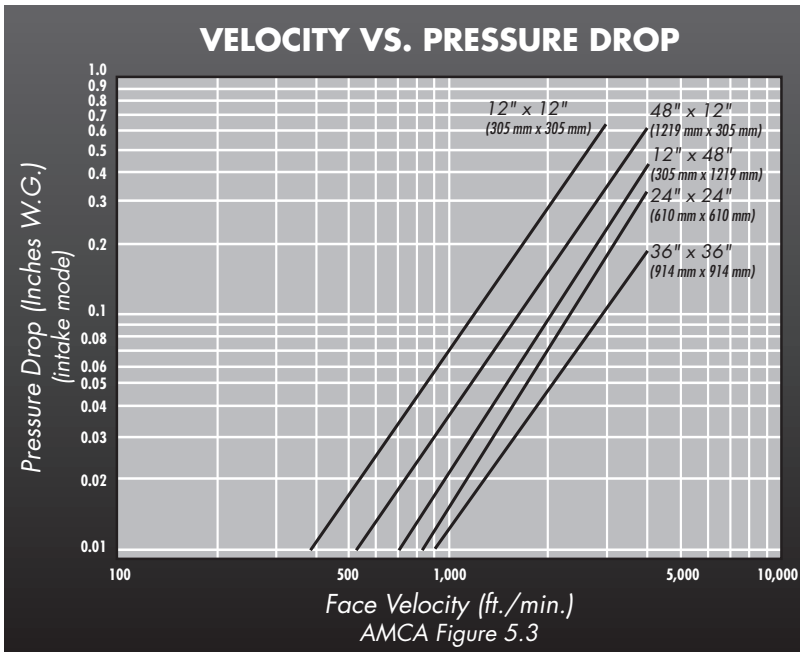

Series 1000 dampers exceeding the maximum design pressure due to blade length may be used by reducing the width of the damper sections and/or by increasing the number of sections per damper to maintain a blade width compatible with the required system pressure.

(Example: 1 section damper of 60" w X 36" h (1525mm x 914mm) at 5" (1.24kPa) w.g. would need to be built in 2 sections of 30" w X 36" h (762mm x 914mm).)