

# **M o t o r** **Guidelines**

**for Belted Applications**

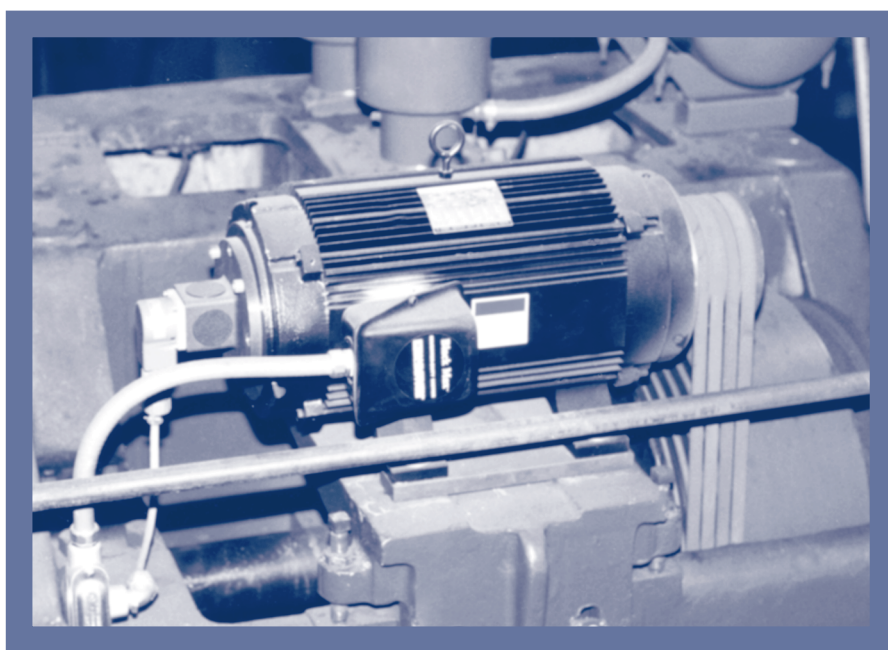

 **MARATHON<sup>®</sup>**  
**ELECTRIC**

*A Subsidiary of Regal-Beloit Corporation*

*Motors for the Long Run!*

**NOTE:** The information contained in this document is intended to be used for applications where Marathon Electric motors are connected to other equipment through the use of a V-belt drive. These recommendations, along with those of the Belt drive manufacturer, are intended to provide maximum life to the motor and to the belting system.

The goal of any belted system is to efficiently transmit the required torque while minimizing the loads on the bearings and shafts of the motor and driven equipment. This can be accomplished by following these four basic guidelines:

1. Use the largest practical sheave diameter.
2. Use the fewest number of belts possible.
3. Keep sheaves as close as possible to support bearings.
4. Tension the belts to the lowest tension that will still transmit the required torque without slipping.

### 1. Sheave Diameter Guidelines

In general, smaller sheaves produce greater shaft stress and shaft deflection due to increased belt tension. See Table 1 for minimum recommended sheave diameters. Using larger sheaves increases the contact with belts which reduces the number of belts required. It also increases the belt speed, resulting in higher system efficiencies. When selecting sheaves, do not exceed the manufacturer's recommended maximum rim speed. Typically 6,500 feet per minute for cast iron sheaves, 8,000 feet per minute for ductile iron and 10,000 feet per minute for steel. The following formula will determine sheave rim speed:

$$\frac{\text{Shaft RPM} \times 3.14 \times \text{Sheave Dia. in inches}}{12}$$

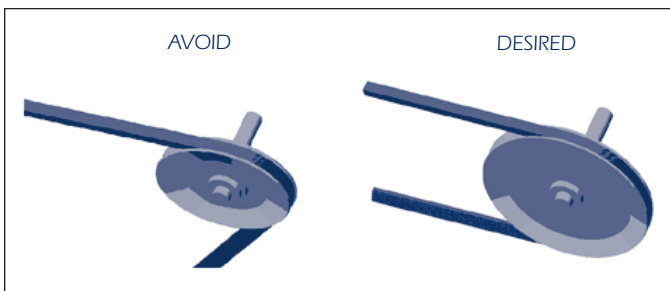

### 2. Number of Belts

In general, use the fewest number of belts that will transmit the required torque without slipping. See Table 1 for maximum recommended number of belts. Each belt adds to the tension in the system which increases load on the shafts and bearings. Belts are most efficient when operated at or near their rated horsepower.

If the sheaves have more grooves than the number of belts required, use the grooves closest to the motor.

### 3. Sheave Location

Install sheaves as close to the housings as possible to increase the bearing life of the motor and driven equipment.

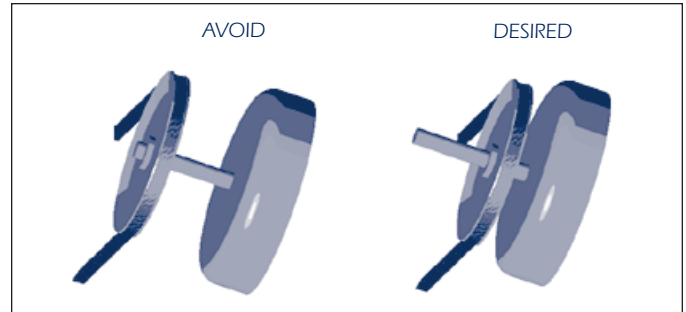

### 4. Belt Tension

In general, belt tensions are to be kept as loose as possible while still transmitting the required torque without slipping. Belt tensions must be measured with a belt tension gage. These inexpensive gages may be obtained through belt manufacturers, or distributors.

Proper belt tension is determined by measuring the required force to deflect the center of the belt a given distance. The proper deflection (in inches) is determined by dividing the belt span in inches by 64. Calculate the proper deflection and then see Table 1 for the required belt deflected force to achieve the calculated deflection.

After tensioning the belt, rotate the sheaves for several rotations or start the system and run for a few minutes if possible to seat belts into the grooves, then re-tension the belts.

Belt tensioning by feel is NOT acceptable. Tensioning by "feel" can be very misleading, and can damage equipment. New belts will stretch during use, and should be retensioned after the first eight hours of use.

#### BELT TENSIONING PROCEDURE

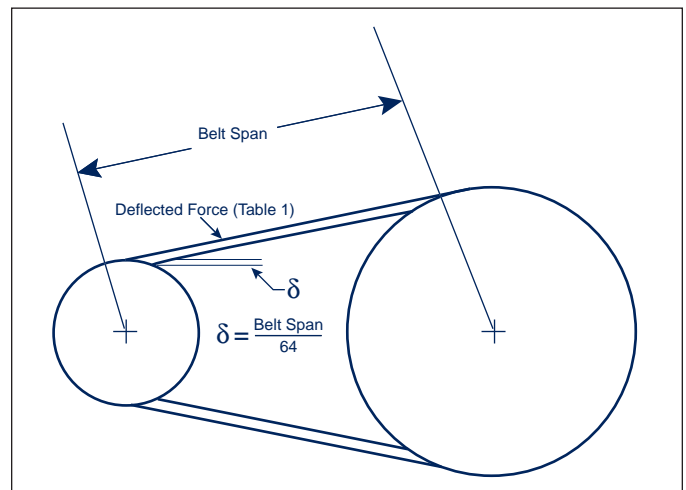

**Table 1: Recommended Sheave Diameters, Belt Type and Number of Belts**

Motor Hp	1200 rpm				1800 rpm				3600 rpm			
	Min. Sheave Dia. (in.)	Belt Type	Max. # of Belts	Belt Deflected Force (lbs.)	Min. Sheave Dia. (in.)	Belt Type	Max. # of Belts	Belt Deflected Force (lbs.)	Min. Sheave Dia. (in.)	Belt Type	Max. # of Belts	Belt Deflected Force (lbs.)
0.75	2.2	3VX	1	3.4	2.2	3VX	1	2.2	2.2	3VX	1	1.3
1	2.4	3VX	1	4.0	2.2	3VX	1	3.1	2.2	3VX	1	1.6
1.5	2.4	3VX	2	3.1	2.4	3VX	2	2.1	2.2	3VX	1	2.5
2	2.4	3VX	3	2.8	2.4	3VX	2	2.9	2.4	3VX	1	2.7
3	3.0	3VX	2	2.9	2.4	3VX	3	2.9	2.4	3VX	2	2.3
5	3.0	3VX	3	4.0	3.0	3VX	3	3.7	2.4	3VX	3	2.5
7.5	3.8	3VX	4	4.7	3.0	3VX	4	4.1	3.0	3VX	2	4.2
10	4.4	3VX	4	5.4	3.8	3VX	4	4.3	3.0	3VX	3	3.8
15	4.4	3VX	5	5.4	4.4	3VX	4	5.4	3.8	3VX	3	4.4
20	5.2	3VX	6	6.0	4.4	3VX	6	4.8	4.4	3VX	3	5.0
25	6.0	3VX	7	5.6	4.4	3VX	7	5.2	4.4	3VX	4	4.7
30	6.8	3VX	7	6.0	5.2	3VX	7	5.3				
40	6.8	5VX	4	12	6.0	3VX	7	6.0				
50	8.2	5VX	4	14.5	6.8	3VX	8	6.0				
60	8.2	5VX	5	14	7.4	5VX	4	13.5				
75	10.0	5VX	5	14.5	8.6	5VX	4	14.5				
100	10.0	5VX	6	16	8.6	5VX	6	13				
125	12.0	5V	7	14	10.5	5V	6	13				
150	13.2	5V	7	15.5	10.5	5V	7	13.5				
200	15.0	5V	8	16	13.2	5V	8	13	NEMA sheave sizes			
250	15.0	8V	6	28	14.0	5V	9	14	Above - NEMA Sheave sizes			
300	16.0	8V	7	27	14.0	5V/8V	11 / 7	14 / 24				
350	16.5	8V	7	30	14.5	5V/8V	12 / 7	14 / 26				
400	17.5	8V	8	29	15.0	5V/8V	13 / 8	15 / 26				
450	18	8V	8	32	16.0	5V/8V	14 / 9	15 / 25	Exceeds cast iron sheave rim speed – special sheave material required			
500	18.5	8V	9	31	16.5	5V/8V	15 / 9	15 / 27				
600					17.5	8V	11	26				
700					19.0	8V	12	27				
800					20.0	8V	13	28				

**Notes:**

1. Horsepowers are nameplate motor horsepowers, and RPMs are motor (driver) speeds.
2. NEMA minimum sheave diameters are from NEMA MG 1, Part 14, Table 14-1.
3. Consult Marathon Electric for applications utilizing (1) smaller sheaves and/or more belts than specified (2) variable speed applications (3) values outside these recommendations.
4. Selections are based on a 1.4 service factor, 5 to 1 speed ratio and various Power Transmission Manufacturer's catalogs used as reference.
5. These selections are for Narrow V-belt sections only. Consult Marathon Electric for details on conventional V-belt sections (A, B, C, D and E), or other belt types.
6. Belt deflected force is per section 4 of this document and is the average force required to deflect the center of a belt 1/64 of the belt span distance. Tolerance on this force is ± 0.5 lbf. for forces ≤ 6 lbs, and ± 2 lbf. for forces > 6 lbs.

The information contained in this document is intended to be used for applications where Marathon Electric motors are connected to other equipment through the use of a V-belt drive. These are to be used as guidelines only since Marathon Electric does not warrant the complete drive system.

### Contact Application Engineering



*Marathon Electric Manufacturing Company*  
A Subsidiary of Regal-Beloit Corporation  
100 E. Randolph Street • P.O. Box 8003  
Wausau, WI 54402-8003 U.S.A.  
Ph. (715) 675-3311 • Fax: (715) 675-8026  
[www.marathonelectric.com](http://www.marathonelectric.com)



Marathon  
Electric  
Recycles



SB528  
2769M/6-00/2500/BP/SB