

Mounting Methods Guide

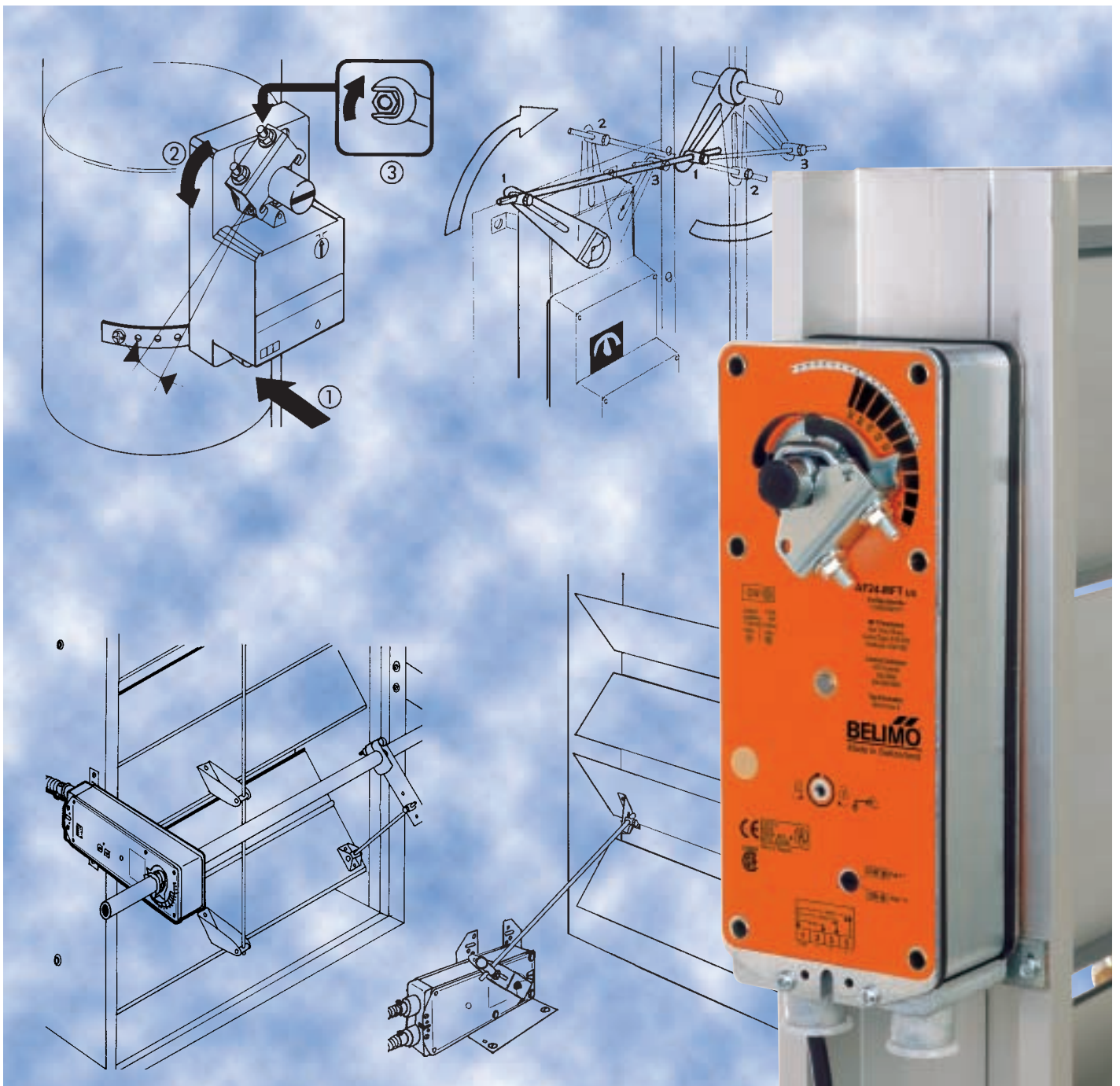

INTRODUCTION

Belimo makes easy-to-mount actuators	3
--	---

SECTION 1 - MOUNTING HARDWARE - an overview

Anti-rotation strap	4
AV 10-18 Universal shaft extension	4
Universal mounting clamp	5
ZDB. . Angle of rotation limiter	5
KH. . Universal crank arm	5
KG6, KG8, KG10 ball joints.....	5
ZG100, ZG101, Universal mounting brackets.....	5
ZG103, ZG104, ZG105 Universal mounting brackets.....	5
ZG-102 Multiple actuator mounting bracket	5
ZG106, ZG107, ZG108 Universal mounting brackets.....	5
KH-AF Crankarm for AF/NF	6
ZG-AF, ZG-SM2, ZG-GM2 Damper linkage kits	6
ZG-NM2 Damper linkage kit.....	7
ZS-100 Weather shield.....	7
ZS-150 Polycarbonate Weather shield.....	7
ZS-200/250 Explosion-proof housing.....	7
ZS-300 NEMA 4x housing.....	7
ZG-JSA Jack shaft adaptor	7

SECTION 2 - DIRECT COUPLED APPLICATIONS

Fail-safe mounting for spring return actuators.....	8
Single damper mounting	9,10
Multiple actuator mounting	9,10
Multiple dampers connected to one actuator with linkage.....	11
Controlling multiple-section damper assemblies.....	11
Mounting to jackshafts.....	12, 13
VAV applications (LM).....	14
Making dampers airtight	15

SECTION 3 - NON-DIRECT COUPLED APPLICATIONS

Using the universal mounting brackets	16, 17, 18, 19
Mounting actuators to cone-type VAV dampers.....	19
Non-direct coupling to jackshafts	20
Non-direct coupling to inlet vanes	21

SECTION 4 - RETROFIT APPLICATIONS

Using Belimo actuators to replace existing units.....	22
---	----

SECTION 5 - CONDUIT CONNECTIONS

Tips for connections at the actuator	23
--	----

SECTION 6 - DAMPER LINKAGES

Important data to ensure proper operation.....	24, 25
Typical applications with linkages	26

BELIMO DIRECT COUPLED ACTUATORS

We invented the concept and perfected the methods.

Belimo direct coupled actuators were designed to minimize installation cost by what has come to be known as the “Belimo” concept. This concept of directly coupling to the damper shaft was invented in 1975 and was the first of many innovations to make electronic damper actuation the easiest and most reliable method to control airflow in HVAC systems.

Because of the wide range of damper types and installation methods, many accessory products have been developed to make the use of these actuators even more versatile. The Belimo actuator can be used for virtually any new or retrofit application. This means that you can have all of the advantages of the industry’s highest quality actuator available for your next job:

- Easy installation - usually in under 10 minutes
- 2 year warranty starting from the installation date
- Overload proof - motor cannot burn out
- UL and CSA listed
- NEMA housings (NEMA 1 - AF and NF Series; NEMA 2 - NM, SM and GM Series)
- Manual override disengages gears (except AF, NF models)
- ISO 9001 Quality Assurance - the highest level of quality recognition
- Proven average failure rate of less than 0.3%

This book is a collection of actuator-damper installations showing common, and some not-so-common, applications which have been used on real installations. No two jobs are ever alike and it is impossible to give an exact solution in this book for all applications.

You will notice that we have tried to minimize the written instructions associated to the applications shown. The intent of this book is not to provide a text book, but a collection of useful ideas. The drawings shown here are meant to inspire your own imagination for your particular application. Future product developments may further simplify mounting applications shown in this publication. Check with your local distributor or your local Belimo Area Sales Manager to see that you always have the most up-to-date copy of this publication.

We sincerely hope the information in the following pages will make your jobs easier and more profitable. If you have any comments or new applications that you would wish to share with us and your fellow workers in the industry, we would welcome your contributions.



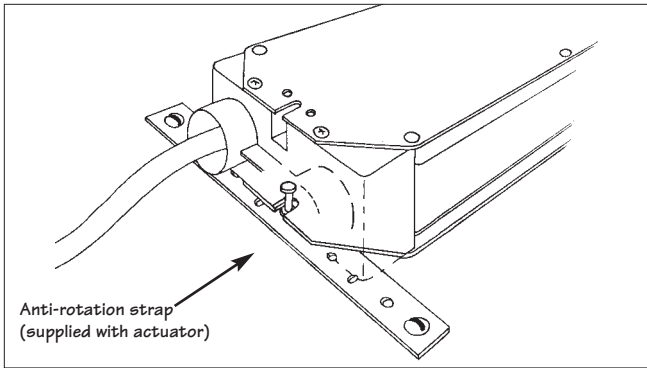

Fig. 1.1 Anti-rotation strap (standard)

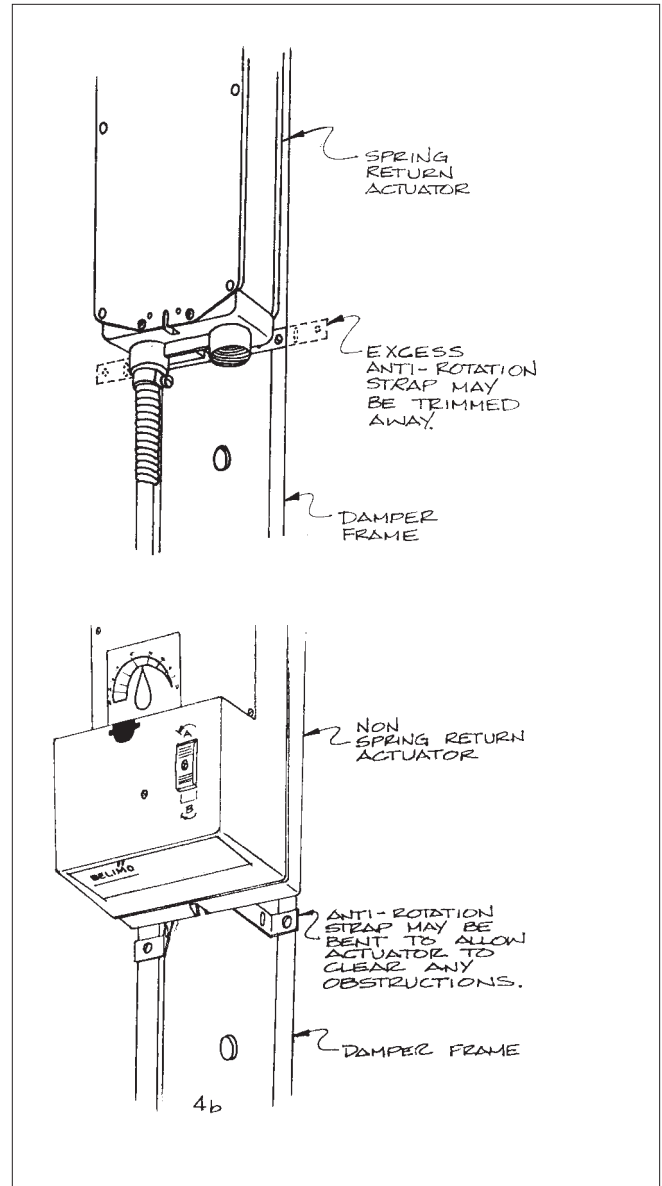

Fig. 1.4 Modification of the antirotation strap

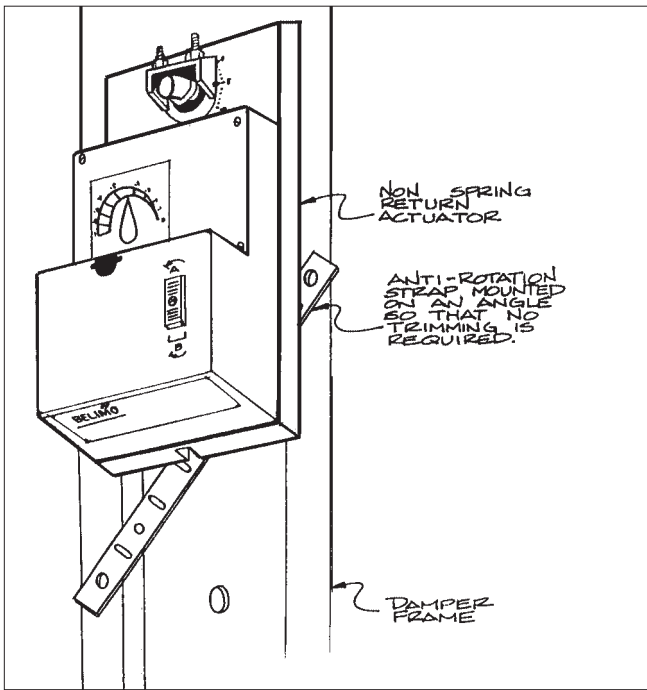

Fig. 1.2 Anti-rotation strap shown mounted on an angle

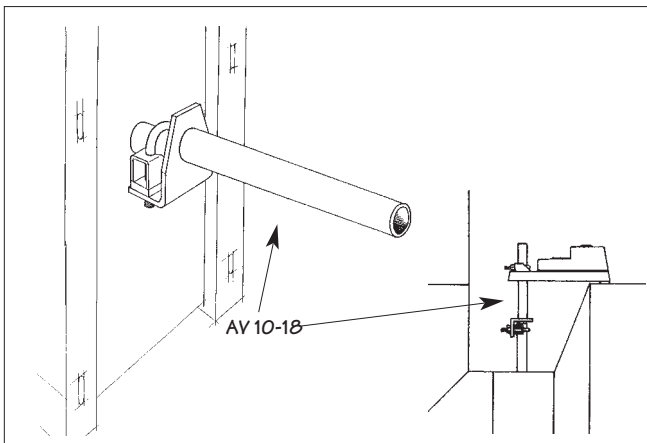

Fig. 1.3 AV10-18 Universal shaft extension - for situations where the shaft may be too short to reach the actuator.

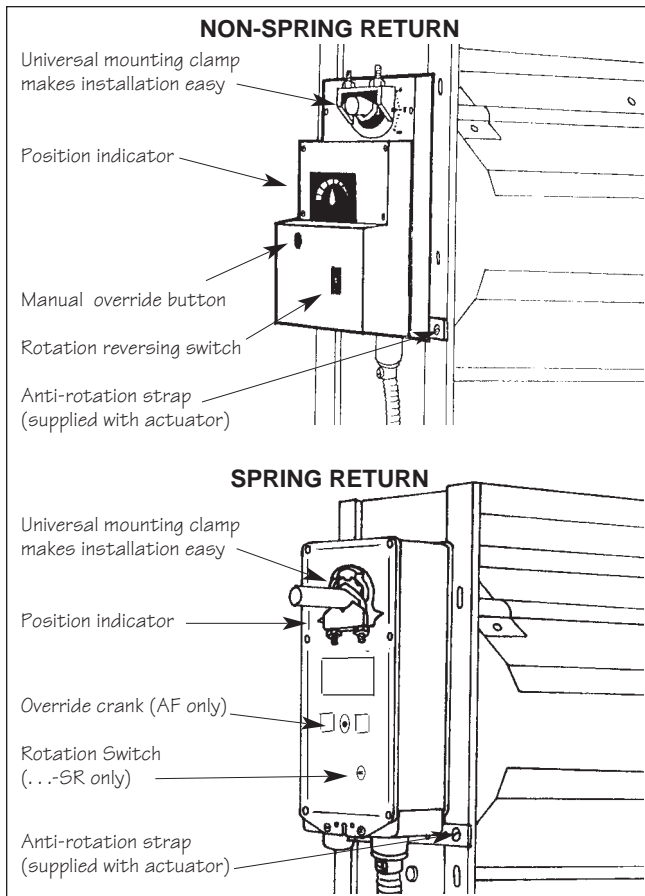

Fig. 1.5 Identifying the major components of Belimo direct coupled actuators

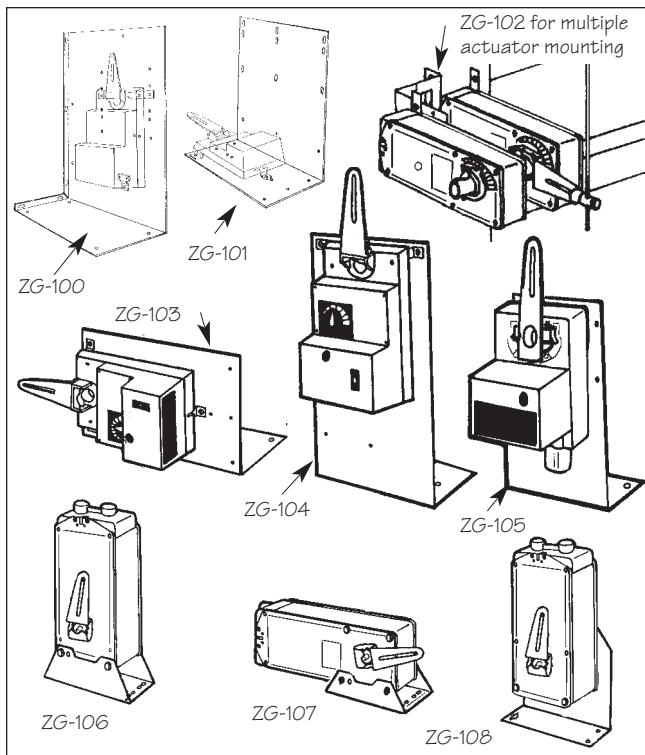

Fig. 1.6 Mounting brackets - for use when direct coupling is impossible.

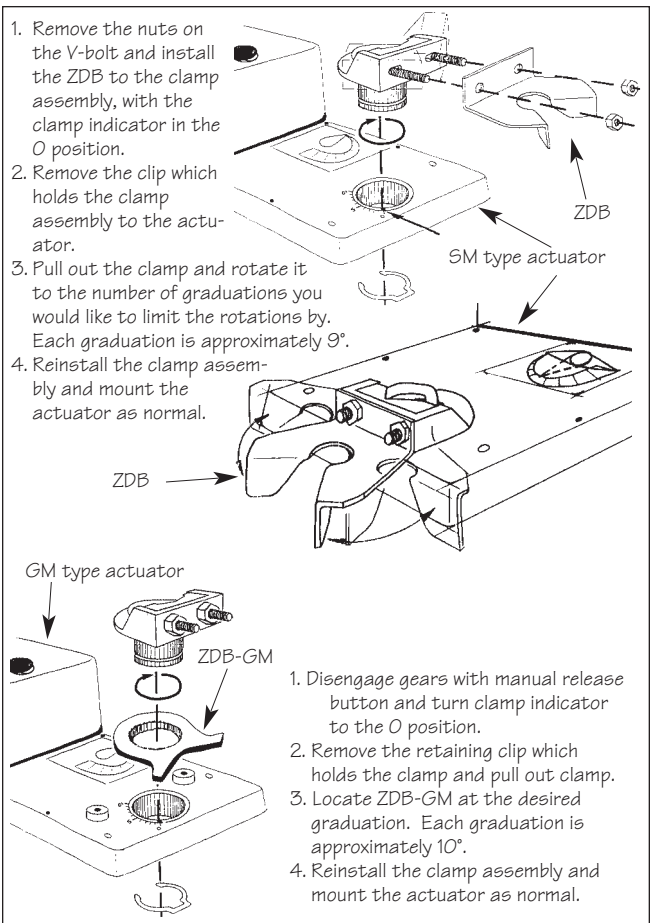

Fig. 1.7 ZDB Angle of rotation limiter - used on the SM an GM actuators to limit the angle of rotation to less than 90°

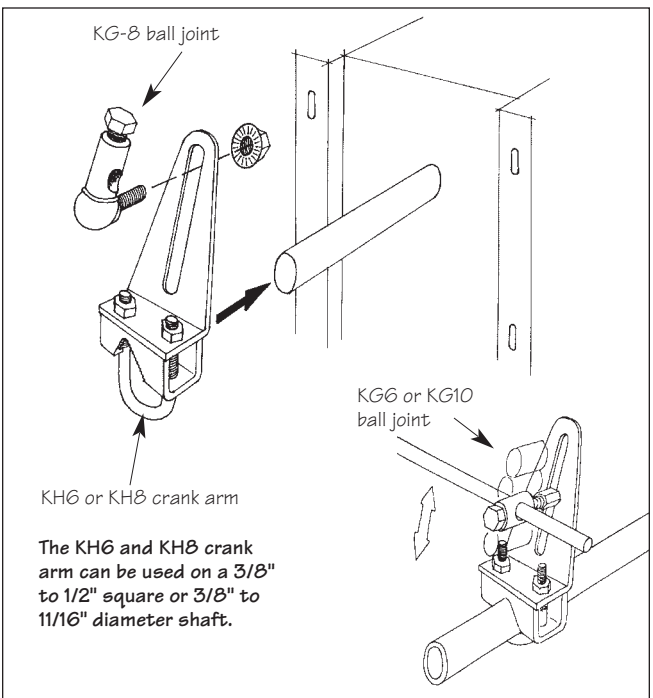

Fig. 1.8 KH.. Universal crank arm - shown with various available ball joints

Linkage kits

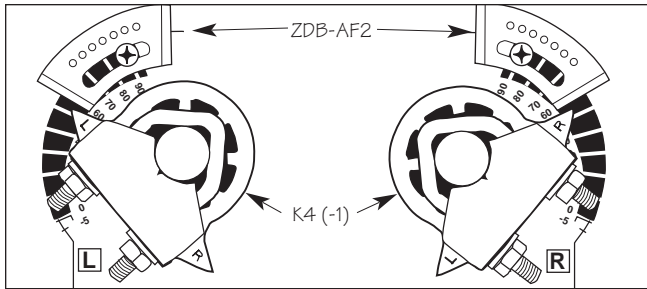

Fig. 1.9 ZDB-AF2 Angle of Rotation Limiter with K4 (-1) clamp for standard shaft mounting using AF/NF actuators.

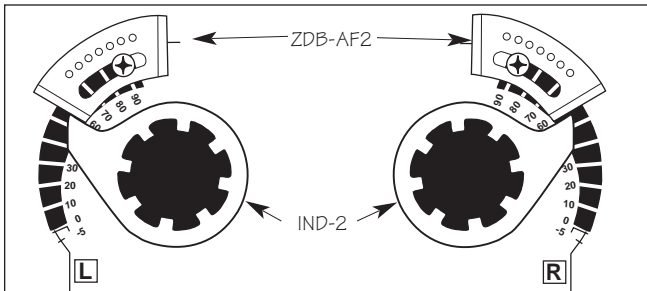

Fig 1.10 ZDB-AF2 Angle of Rotation Limiter with IND-2 indicator for short shaft mounting using AF/NF actuators.

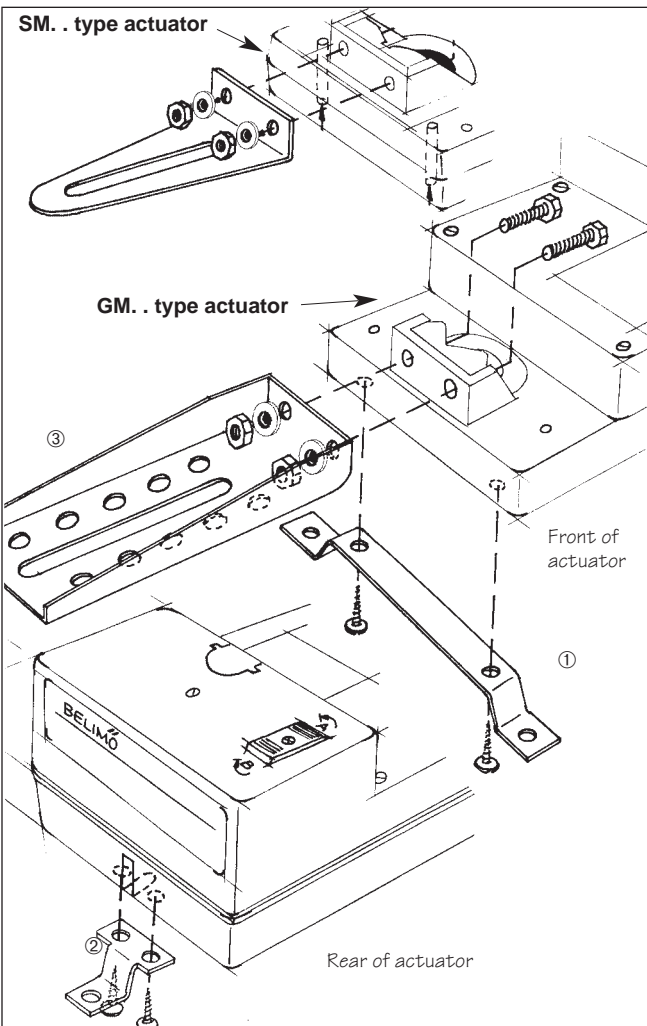

Fig. 1.11 ZG-SM2/ZG-GM2 Damper linkage kit

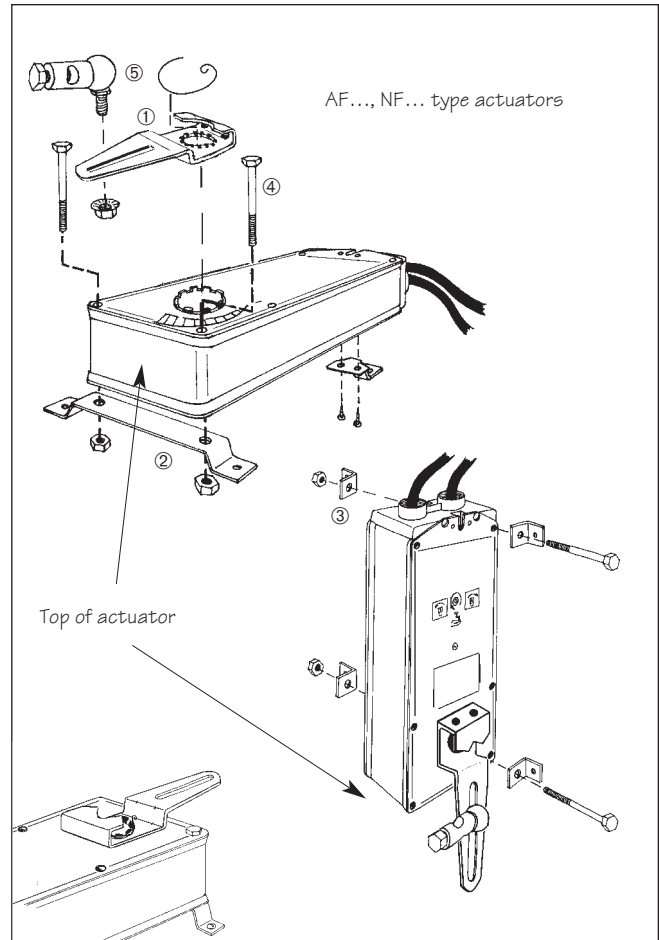

Fig. 1.12 ZG-AF Damper linkage kit Kit contains:
 ① 1 crankarm with retaining clip, ② 2 standoff brackets,
 ③ 4 mounting feet, ④ 2 bolts w/ nuts, ⑤ 2 ball joints

Damper Linkage Kit ZG-..

The damper linkage kits ZG-SM2, ZG-GM2 and ZG-SF are used with the SM 2. . . , FM 2. . . , GM 2. . . , and SF 2. . . direct coupled actuators where a direct coupling of the motor to the damper shaft is not possible.

- | | |
|-----------------------------|------------------------|
| ① – front fixing attachment | ④ (not shown) |
| ② – rear fixing attachment | – 2 ball joints |
| ③ – crank arm | – 2 bolts, M 6 x 16 |
| | – 7 sheet metal screws |

Assembly

- Screw front ① and rear ② attachment onto actuator base plate.
- Remove the V-bolt.
- Mount the actuator crank arm.
- Mount actuator with 3 screws on a rigid base in a suitable position. A clearance of 3/8 [10 mm] between the actuator and mounting surface as well as the 3-point fixing arrangement will ensure proper installation even on uneven mounting surfaces.
- Mount damper linkage and adjust ball joints.

Jack shaft adaptor, Weather shield, Actuator operator handle

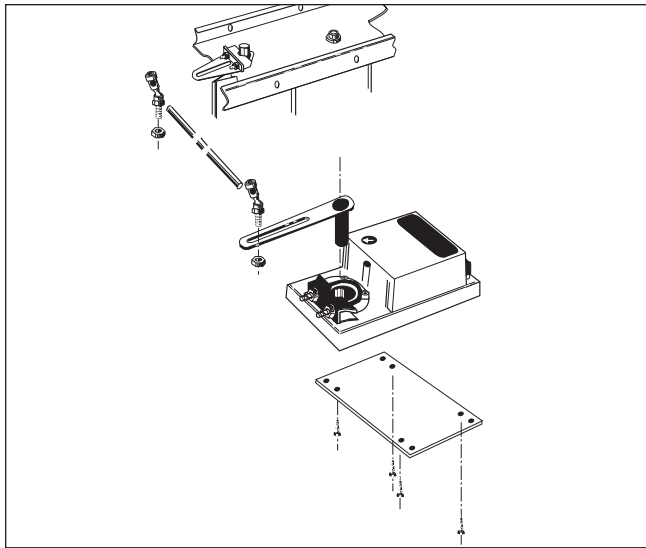

Fig. 1.13 ZG-NM4 Mounting bracket assembly for the NM2 . . actuators

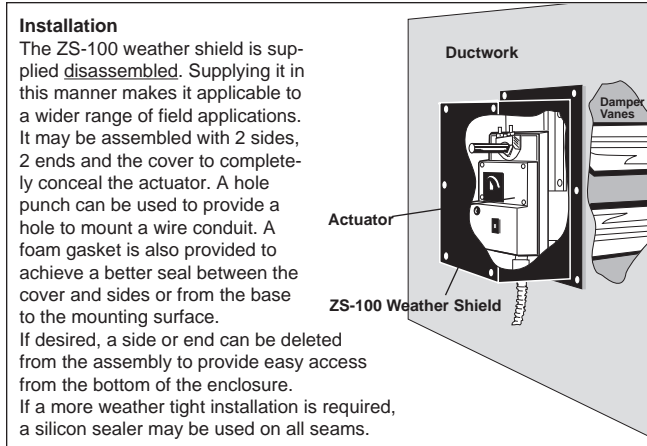

Fig. 1.14 ZS-100 Weather Shield

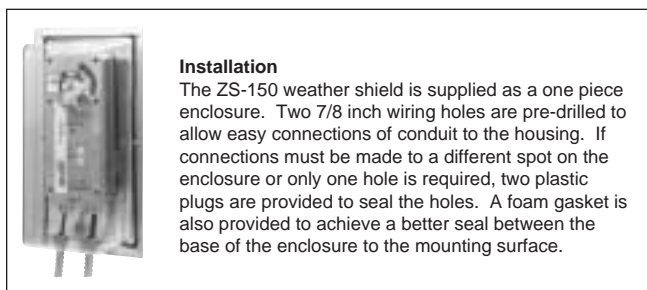

Fig. 1.15 ZS-150 Tinted polycarbonate weather shield

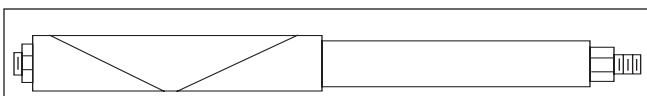

Fig. 1.16 ZG-JSA - ... Jack shaft adaptor. See page 10 for mounting instructions.

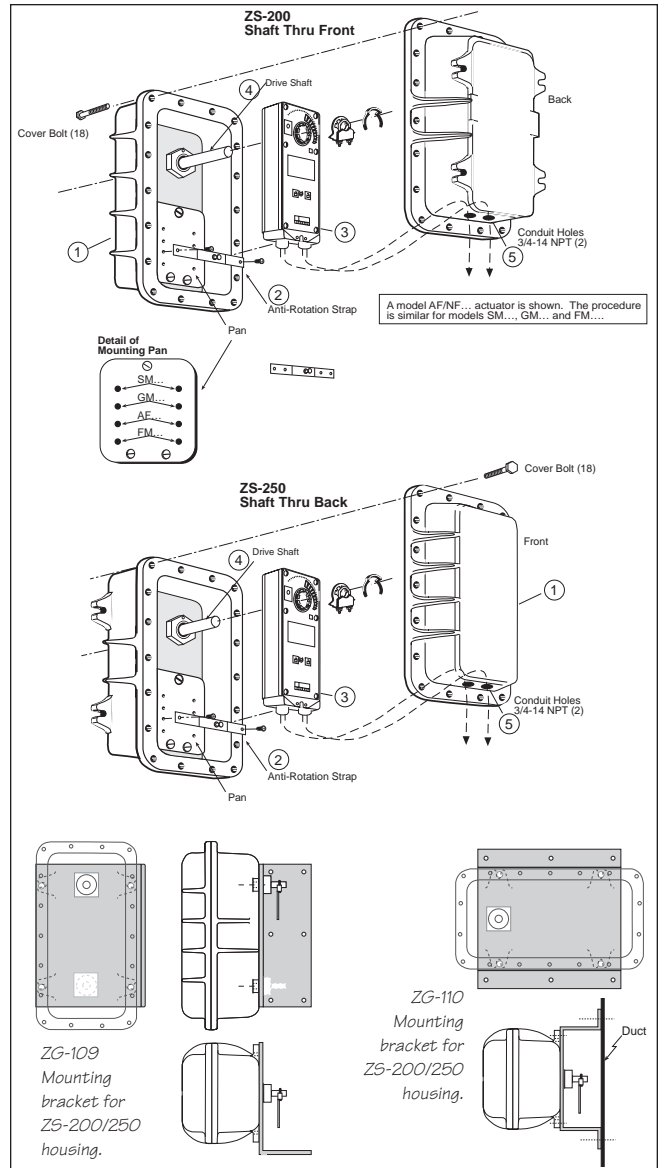

Fig. 1.17 ZS200/250 Explosion-proof housing and ZG-109/ZG-110 available mounting brackets.

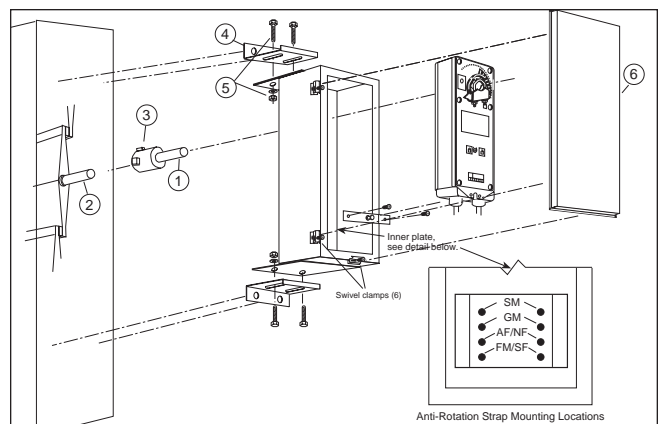

Fig. 1.18 ZS-300 Type 304 stainless steel housing for the toughest environments. NEMA 4X rating.

Section 2 - direct coupled applications

Direct coupled mounting

The four illustrations below show spring return actuator mounting orientation for a fail-safe position damper.

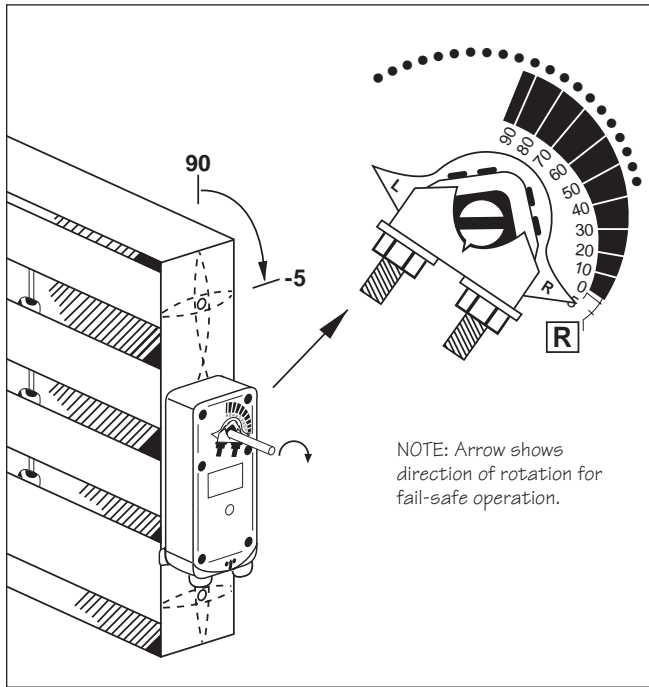

Fig. 2.1 Fail-safe clockwise (CW) to open position

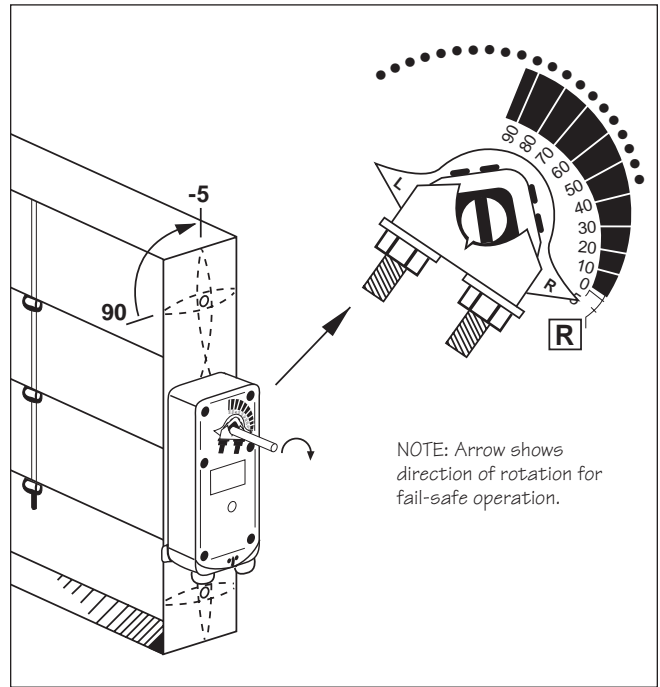

Fig. 2.3 Fail-safe clockwise (CW) to closed position

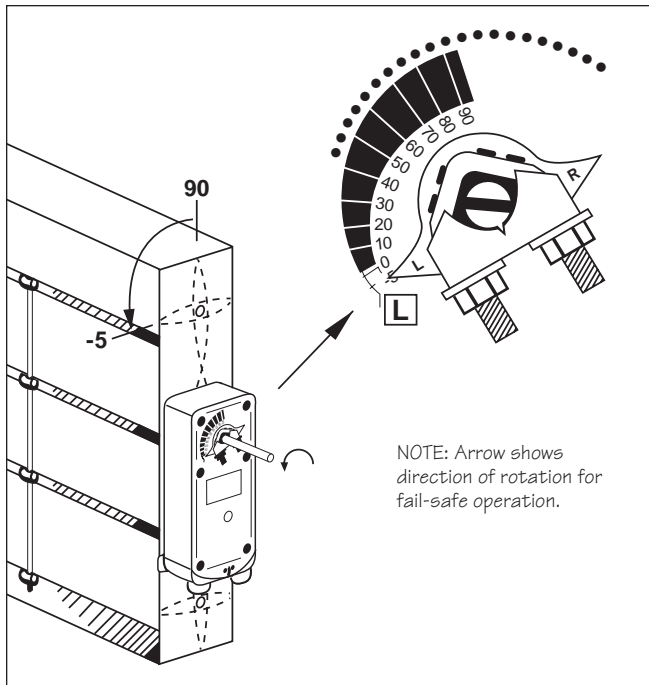

Fig. 2.2 Fail-safe counterclockwise (CCW) to open position

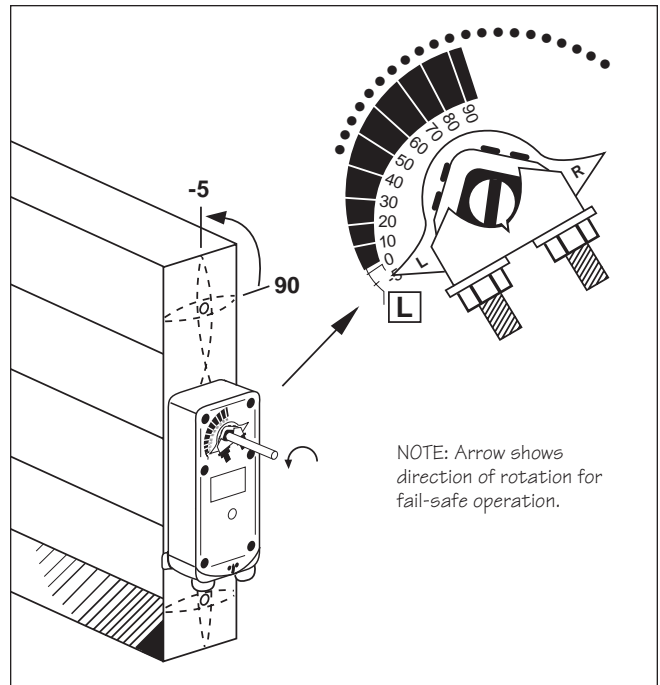

Fig. 2.4 Fail-safe counterclockwise (CCW) to closed position

Direct coupled mounting

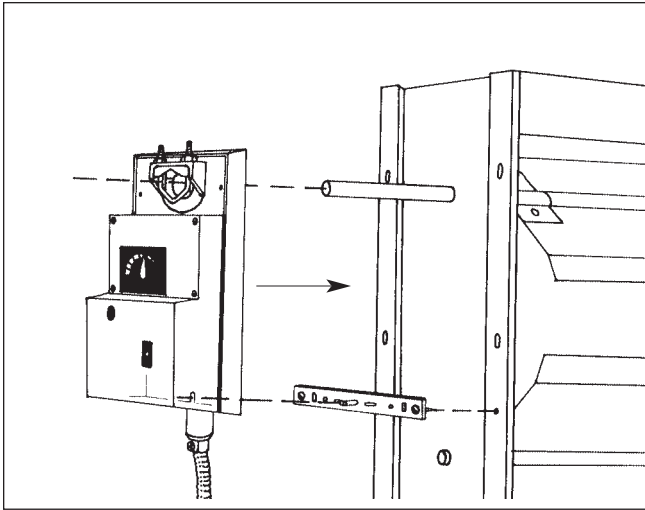

Fig. 2.5 Standard direct coupled mounting

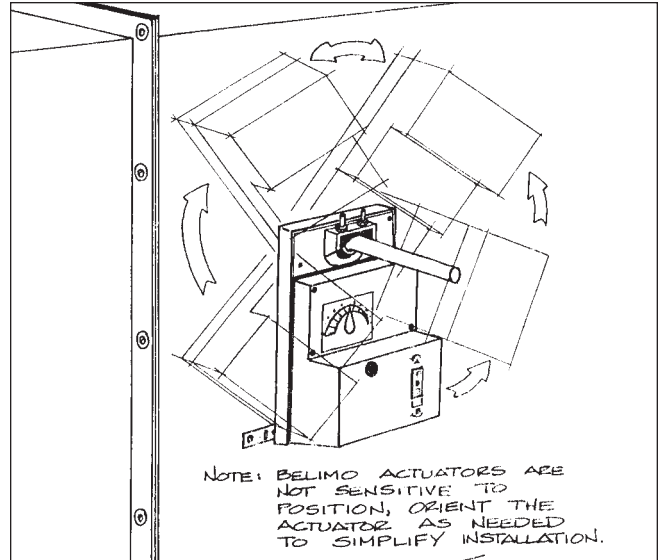

Fig. 2.7 Belimo actuators mount in any position

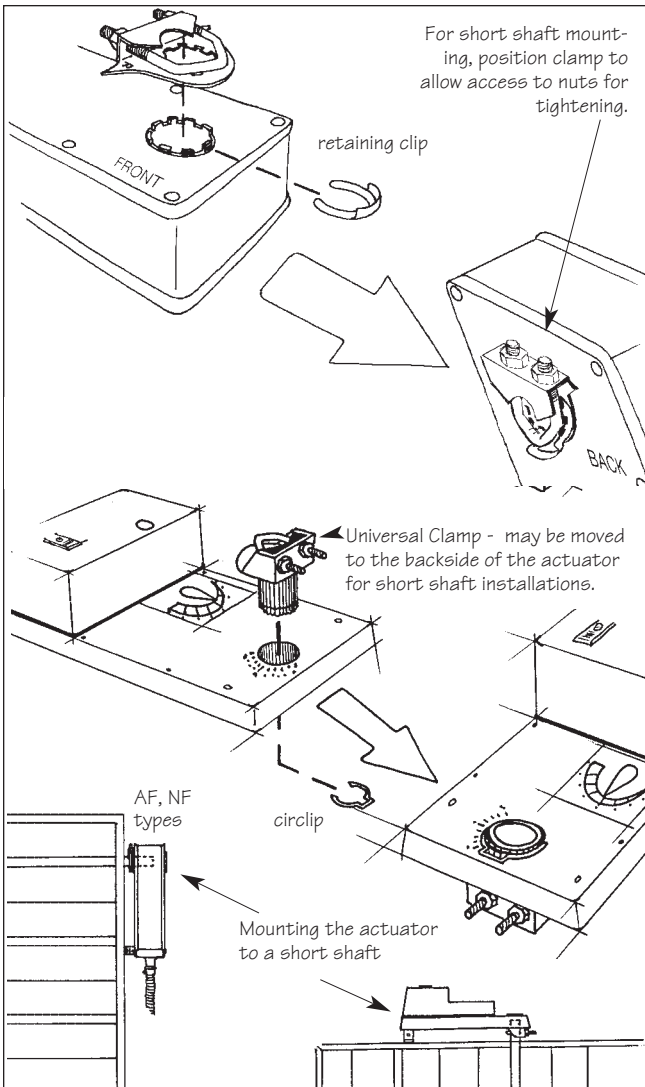

Fig. 2.6 Universal Mounting Clamp - Note that the clamp is most often mounted on the front of the actuator body, but may be moved to the back of the actuator for short-shaft installations.

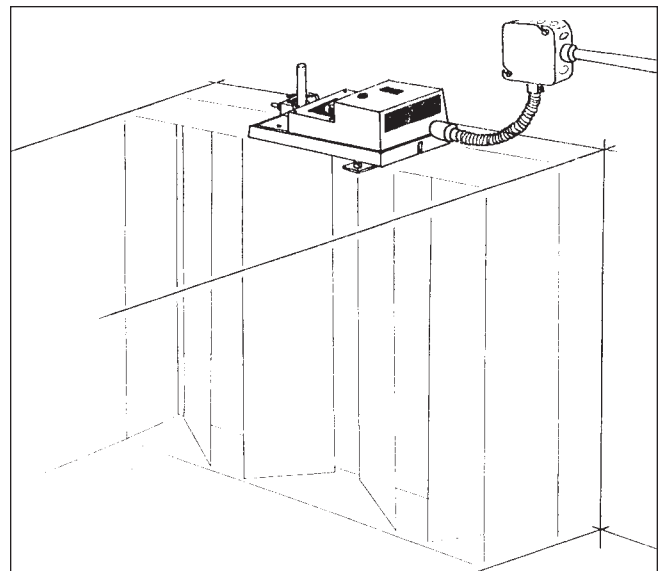

Fig. 2.8 Direct coupled mounting, fastened directly to duct work

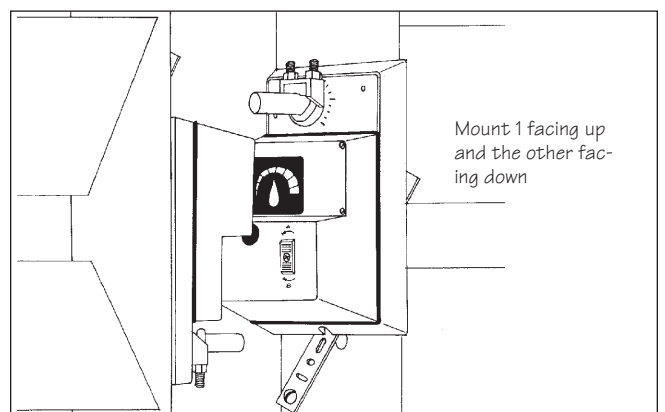

Fig. 2.9 Direct coupled mounting of 2 actuators in close quarters

Section 2 - direct coupled applications

Direct coupled mounting

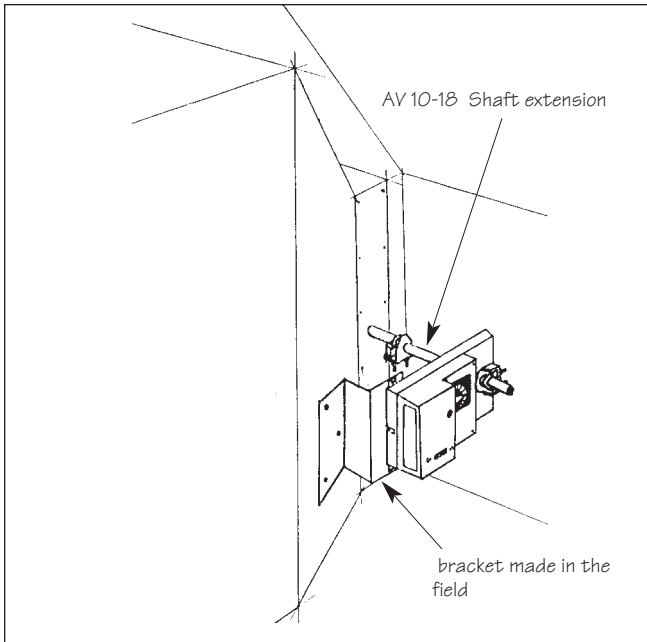

Fig. 2.10 Direct coupled to angular ductwork using an AV 10-18 shaft extension and a bracket which can be fabricated in the field.

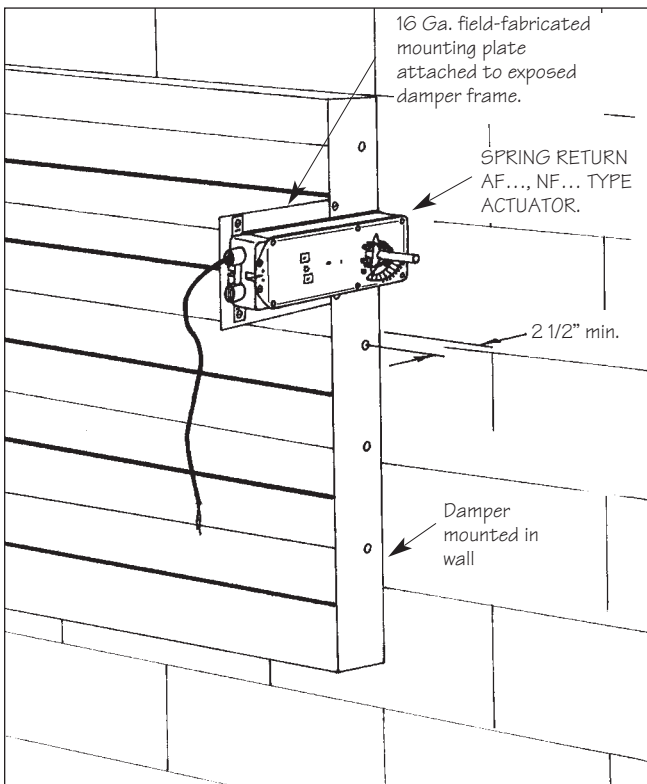

Fig. 2.11 Field fabricated mounting plate used to attach actuator to exposed damper frame. Use this method when there is not enough clearance from wall to mount the actuator in the standard configuration.

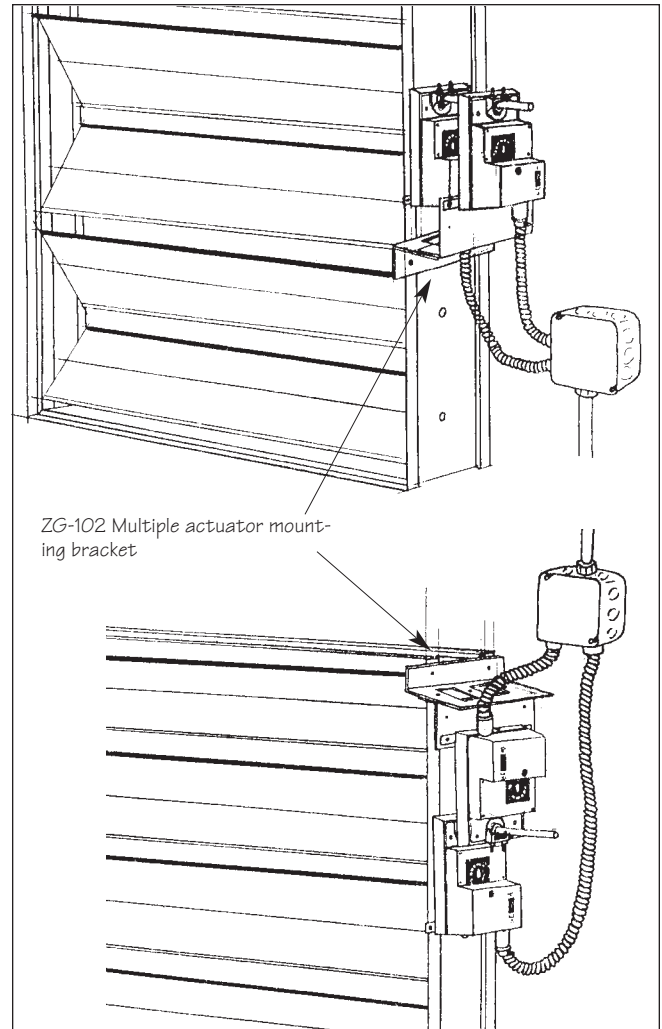

Fig. 2.12 Multiple actuator mounting using the fully adjustable ZG-102 multiple actuator mounting bracket

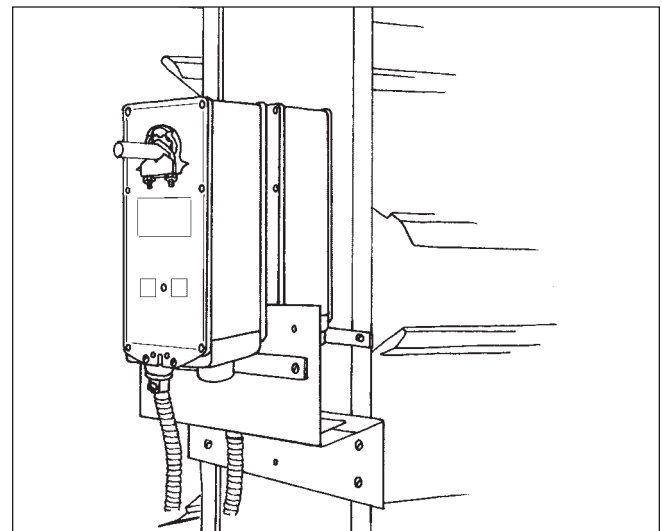

Fig. 2.13 Multiple Actuator Mounting of AF, NF Series actuators. If the damper shaft is too short to extend out of the outer actuator, the short shaft mounting method (see Fig. 2.6) may be used.

Direct coupled mounting for multiple dampers

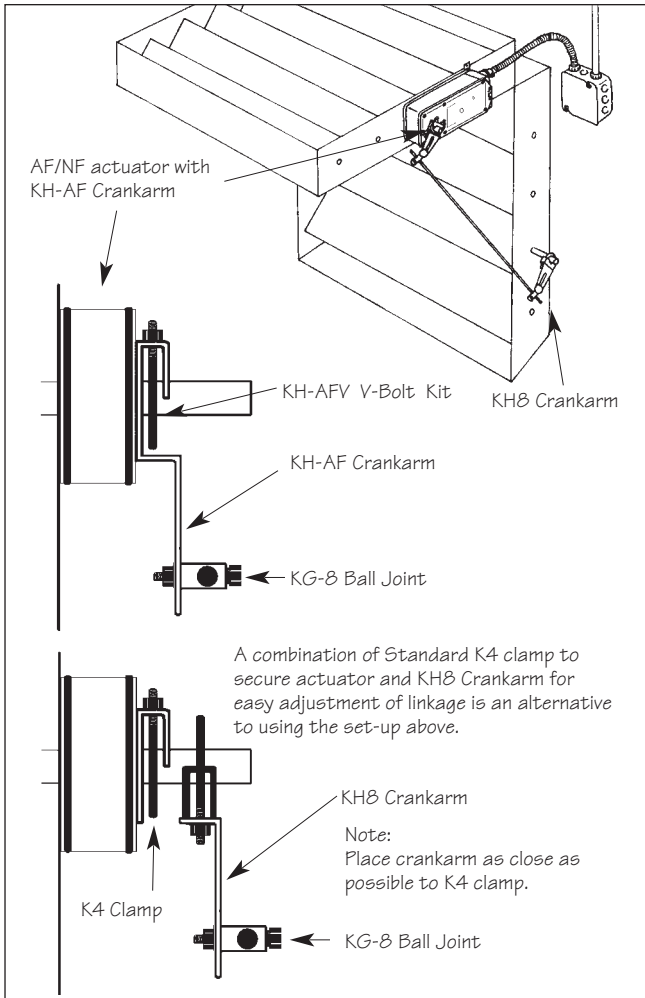

Fig. 2.14 Multiple dampers direct connected to one actuator with linkage to operate the other damper.

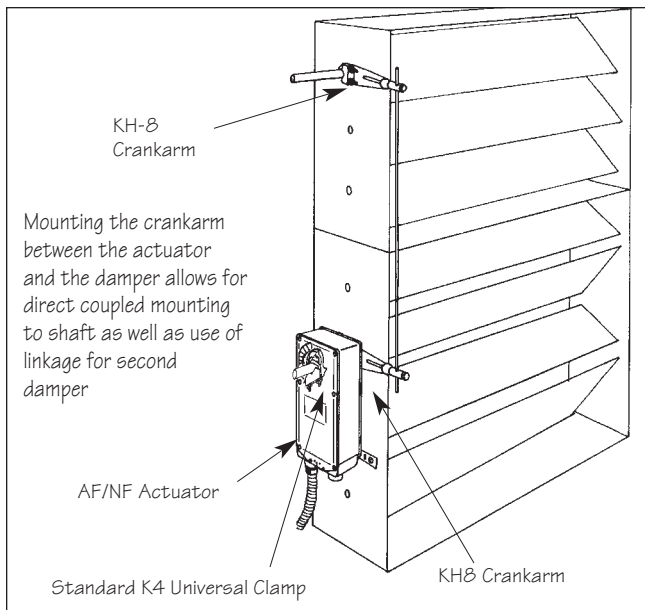

Fig. 2.15 Multiple stacked dampers connected to one actuator with linkage

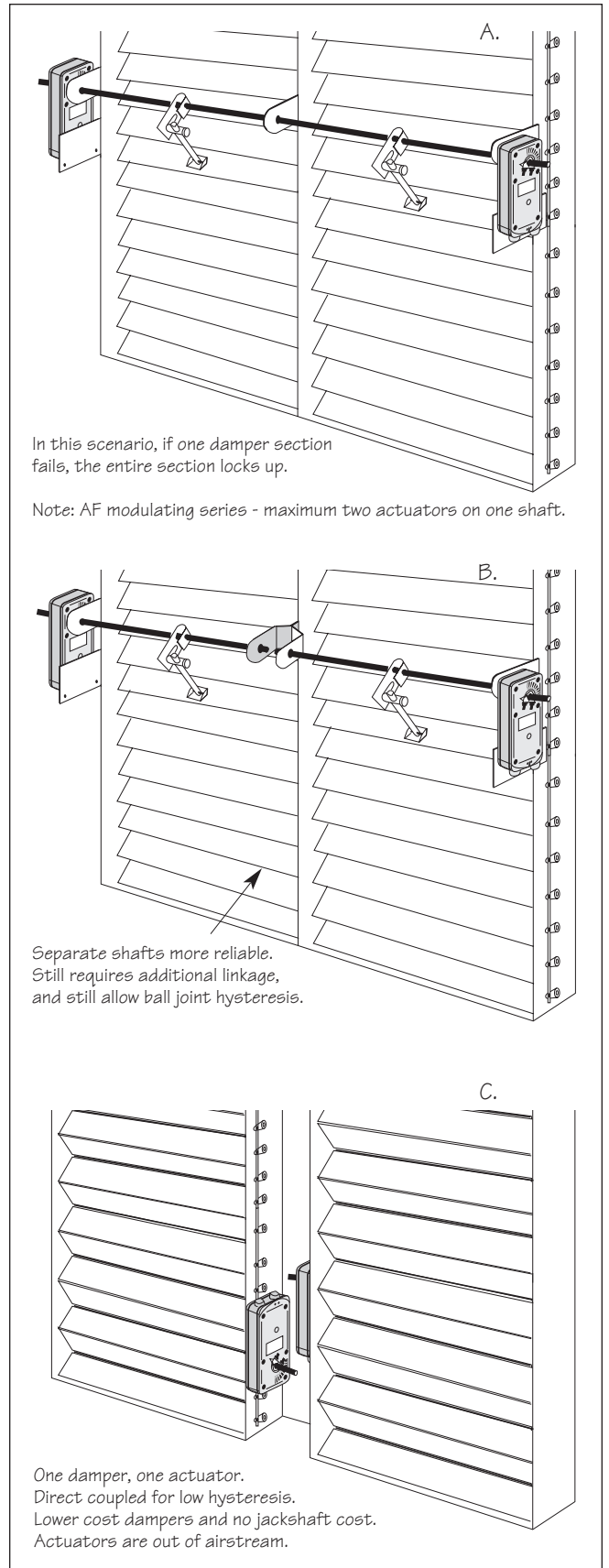

Fig. 2.16 Controlling multiple-section damper assemblies

Section 2 - direct coupled applications

Direct coupled mounting of actuators to dampers with jackshafts

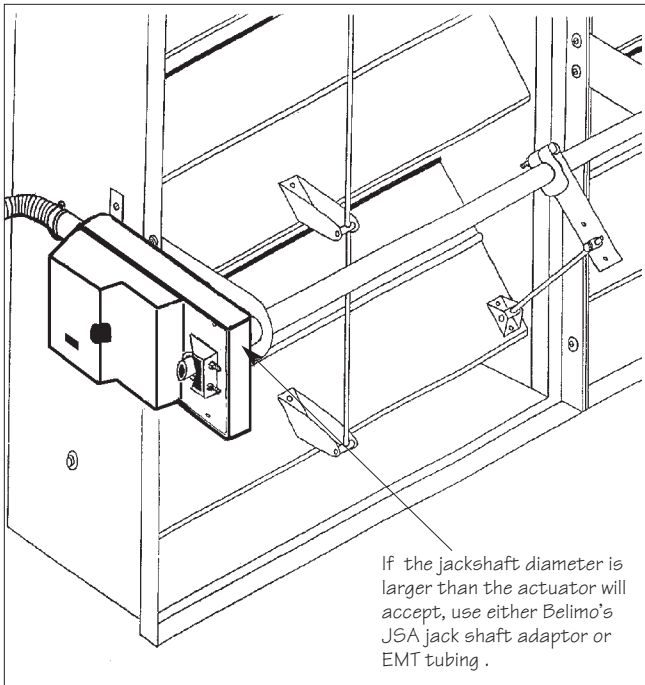

Fig. 2.17 Actuator direct coupled to a jackshaft

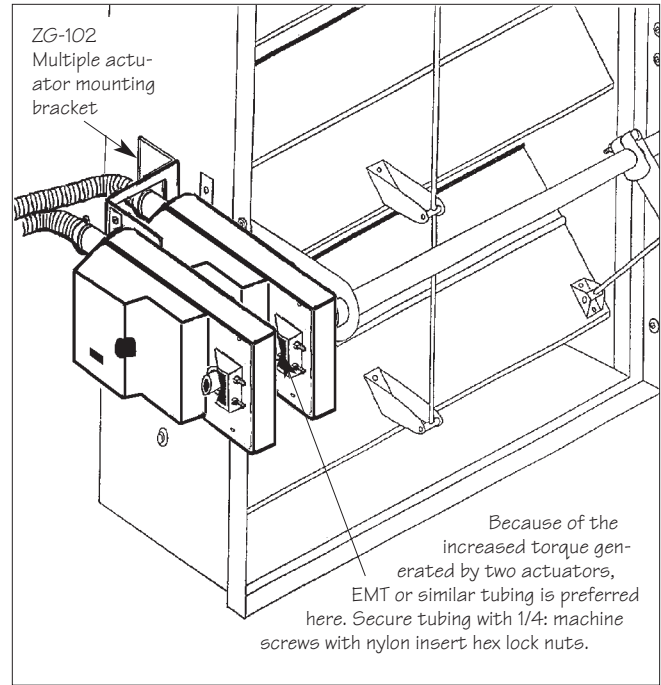

Fig. 2.19 Multiple actuators direct coupled to a jackshaft

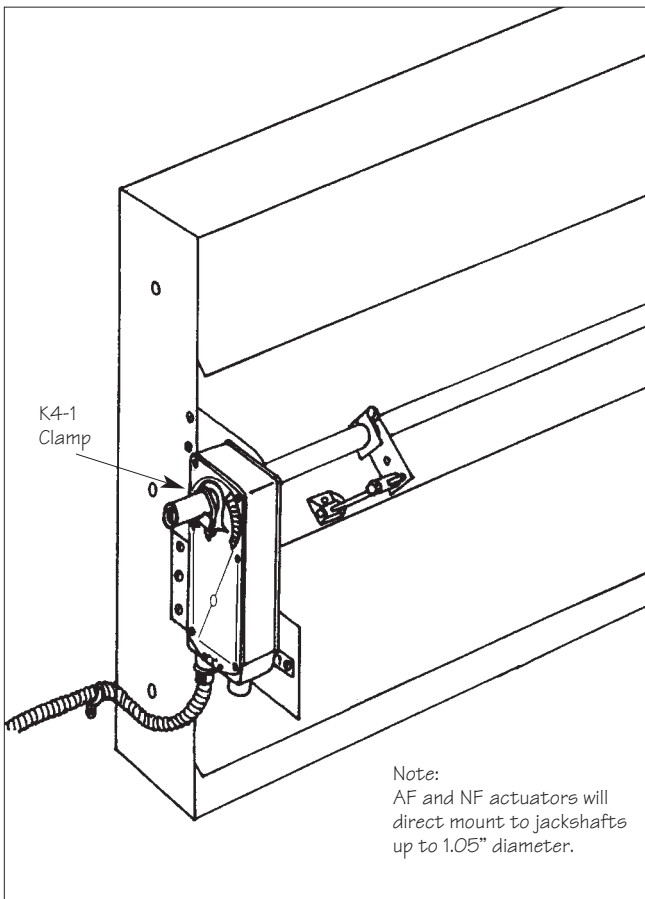

Fig. 2.18 Actuator mounted to ductwork and direct coupled to a jackshaft.

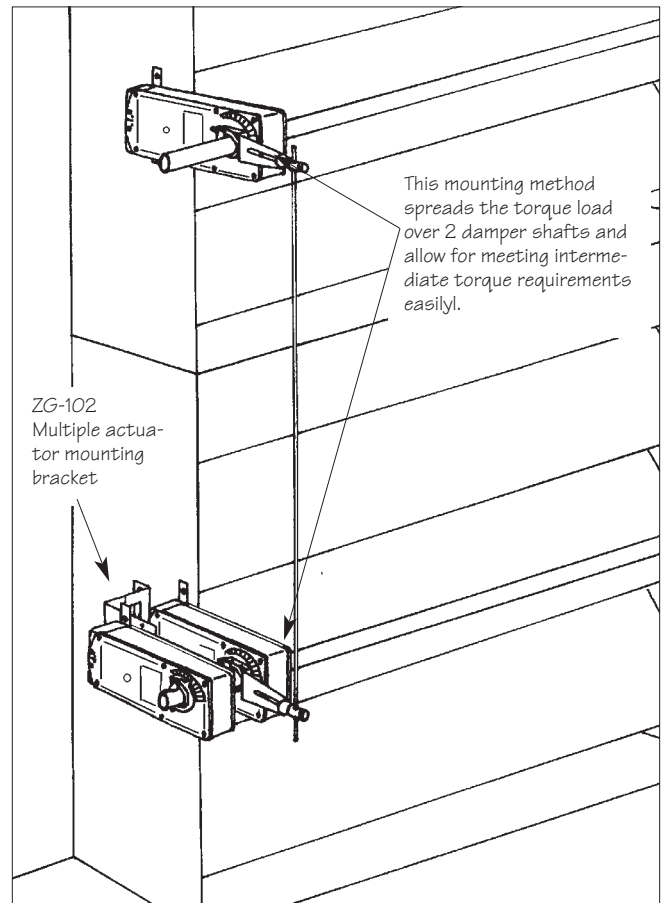

Fig. 2.20 Multiple dampers connected to multiple actuators using linkage. (For 2-position AF actuators only)

Direct coupled mounting of actuators to dampers with jackshafts inside ductwork

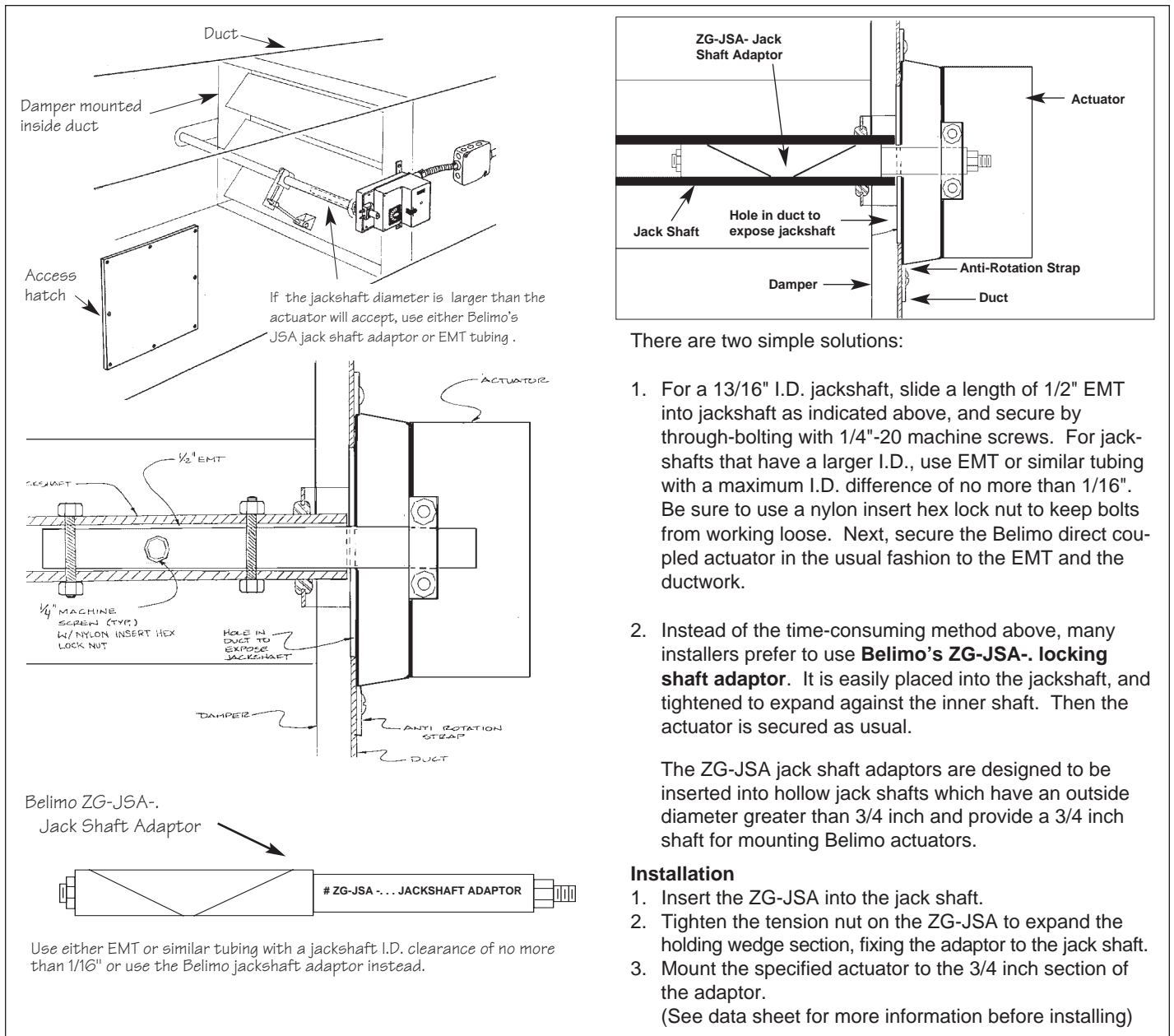

Fig. 2.21 Jackshaft inside ductwork

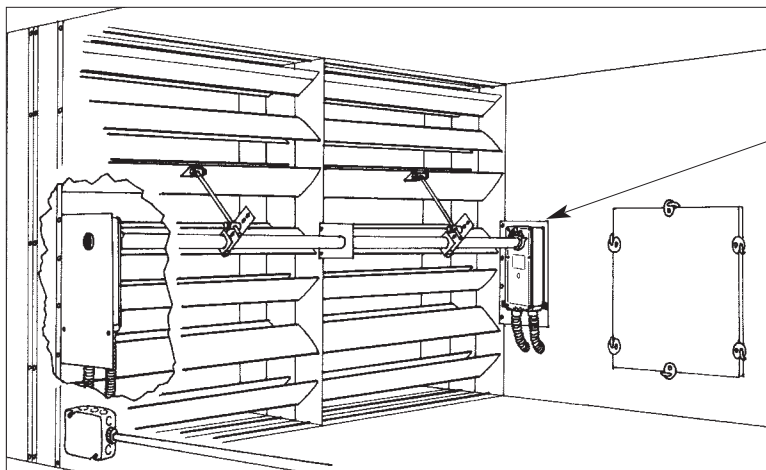

Fig. 2.22 Multiple actuators mounted to the same jackshaft

Before mounting, check for clearance between the damper blade, in the full open position, and the actuator.

An independent actuator per section is the best way to drive this type of damper assembly.

Section 2 - direct coupled applications

VAV applications (LM)

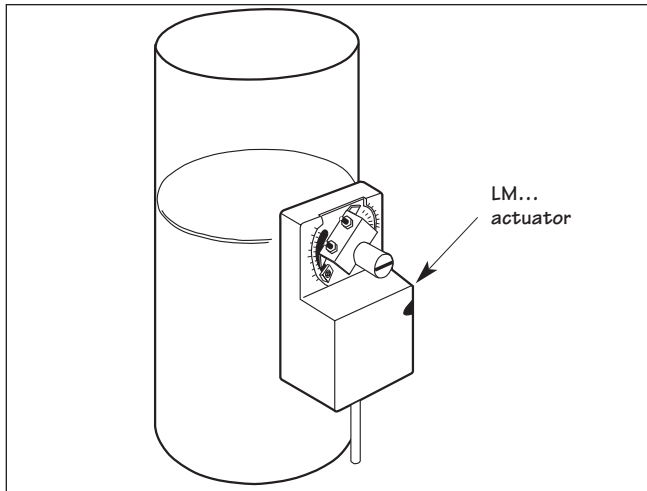

Fig. 2.23 LM type actuator mounted on a round damper.

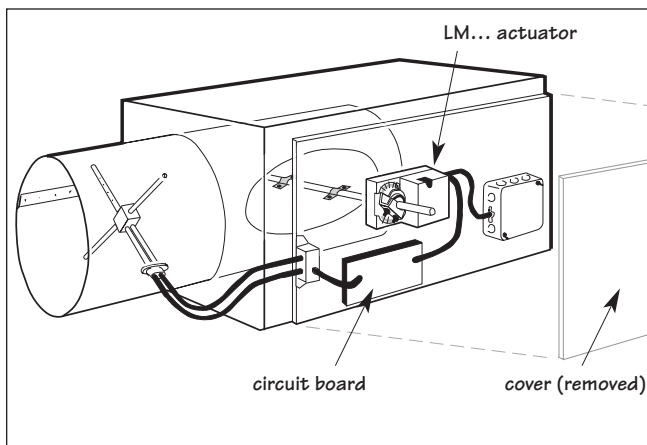

Fig. 2.24 LM type actuator mounted on typical VAV box.

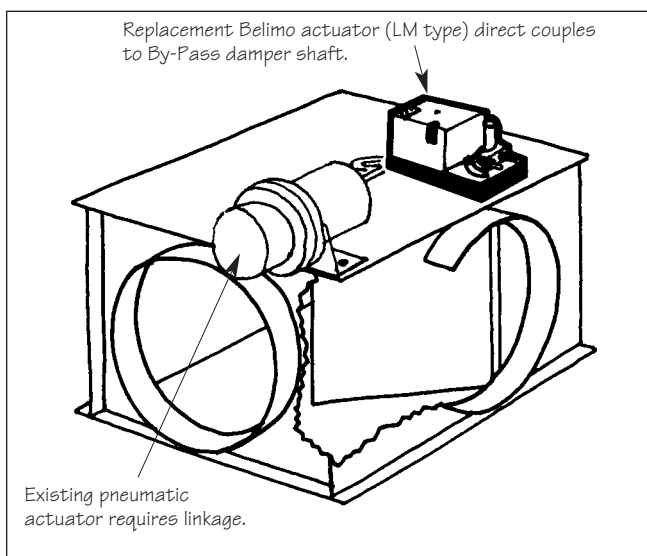

Fig. 2.25 LM type actuator mounted on VAV By-Pass box, replacing pneumatic type.

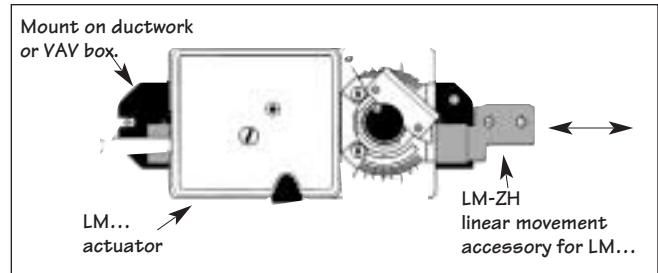

Fig. 2.26 LM-ZH Linear Movement Accessory for LM type actuators.

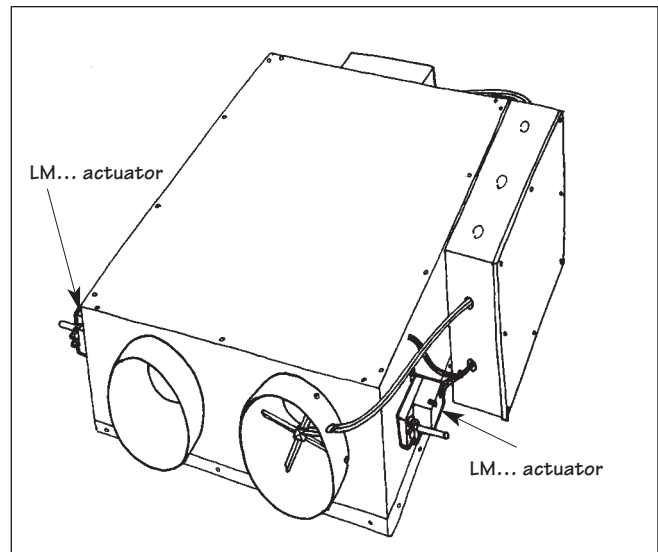

Fig. 2.27 LM type actuator mounted on a VAV dual duct mixing box.

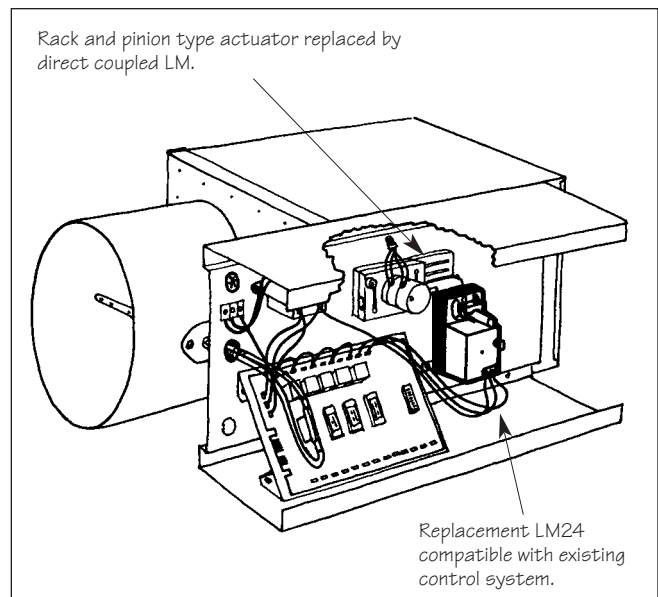
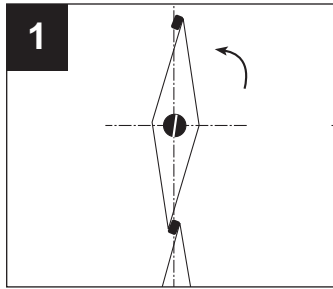

Fig. 2.28 LM type actuator mounted in VAV box, replacing rack and pinion type actuator.

How to make a damper airtight

For Series GM, SM, NM Actuators Without Spring Return,

(Series NM model shown...others are similar)



1 Turn damper blades to their fully closed position.

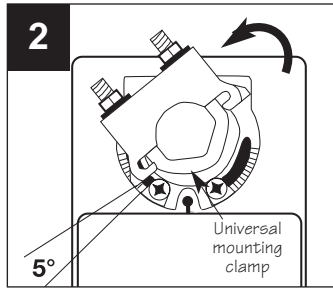

2 With manual override button depressed, rotate actuator clamp to 5° from end position.

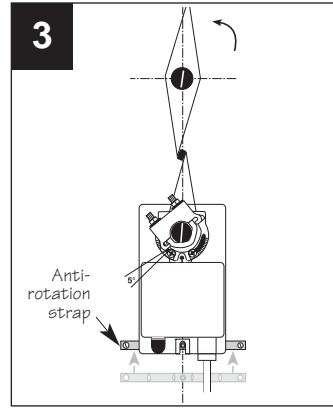

3 Slide actuator over shaft and mount anti-rotation strap.

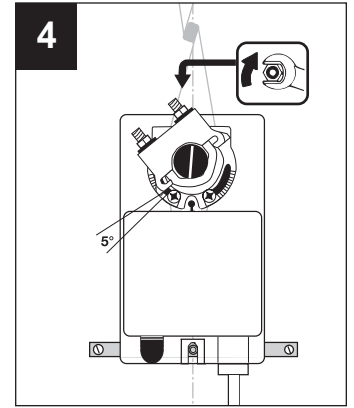

4 Tighten nuts on universal mounting clamp. Actuator will now compress damper blades when reaching end position.

Fig. 2.29

For AF Series Spring Return Actuators - Manual Override / Automatic Airtight Dampers

1. Turn damper blades to their fully closed position. If shaft rotates clockwise, mount actuator with "R" facing out. (CCW, "L" faces out.)
2. Slide the actuator onto the damper shaft and tighten the nuts on the universal clamp. Position indicator should read 0°, as it does when shipped (5° from full fail safe, -5°).
3. Position the anti-rotation strap so that it engages the notch at the bottom of the actuator. Secure to ductwork with self-tapping screws.
4. The actuator will automatically provide tight compression against damper seals, driving from 0° (blades closed by hand) to full fail safe of max. -5° (tight damper seal compression) when...
 - a) ...power is applied to the actuator, or...
 - b) ... the manual override is released with the supplied hand crank (1/4 turn left).

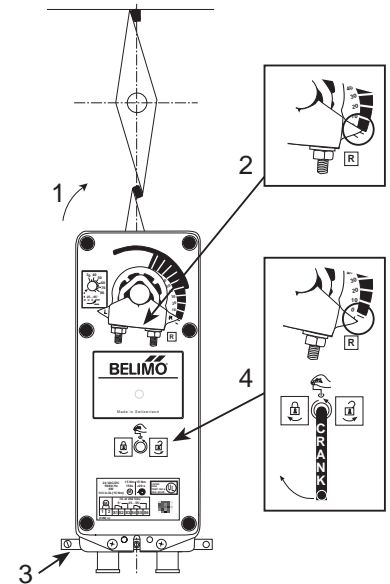

Fig. 2.30

For NF Series Spring Return Actuators

1. Turn damper blades to their fully closed position. If shaft rotates clockwise, mount actuator with "R" facing out. (CCW, "L" faces out.)
2. Slide the actuator onto the damper shaft and tighten the nuts on the universal clamp, only finger-tight.
3. Position the anti-rotation strap so that it engages the notch at the bottom of the actuator. Secure only one side to the ductwork with self-tapping screws. Swing one side of the strap out from under the actuator.
4. With damper blades still closed, rotate the actuator 5° from the end position. tighten nuts on the universal clamp with 10 mm wrench.
5. Rotate the actuator back to the end position, fully compressing the damper seals.
6. Swing anti-rotation strap up and engage the notch on the bottom of the actuator. Secure remaining side to ductwork with self-tapping screw.

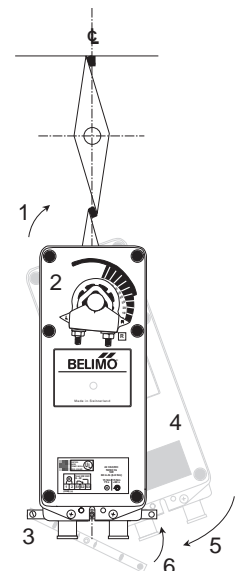

Fig. 2.31

Section 3 - non-direct coupled applications

Using universal mounting brackets with linkage

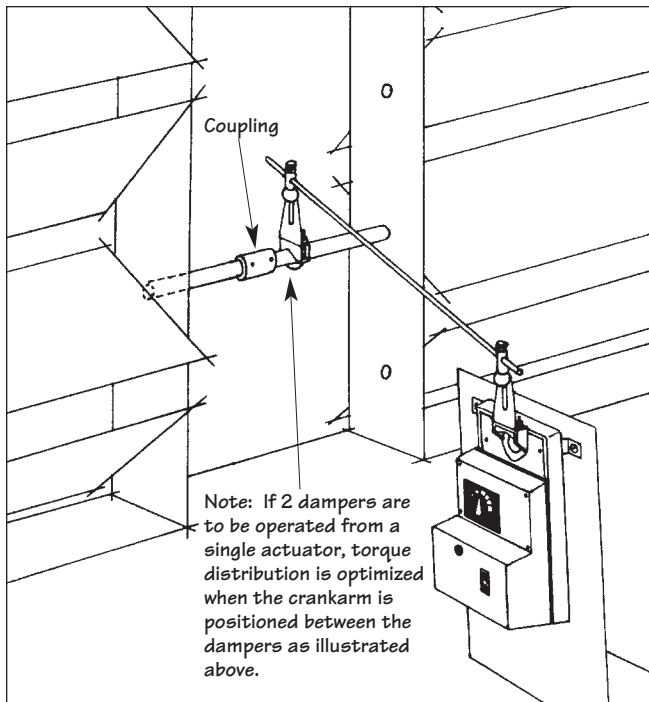

Fig. 3.1 Actuator connected to 2 dampers that share the same shaft.

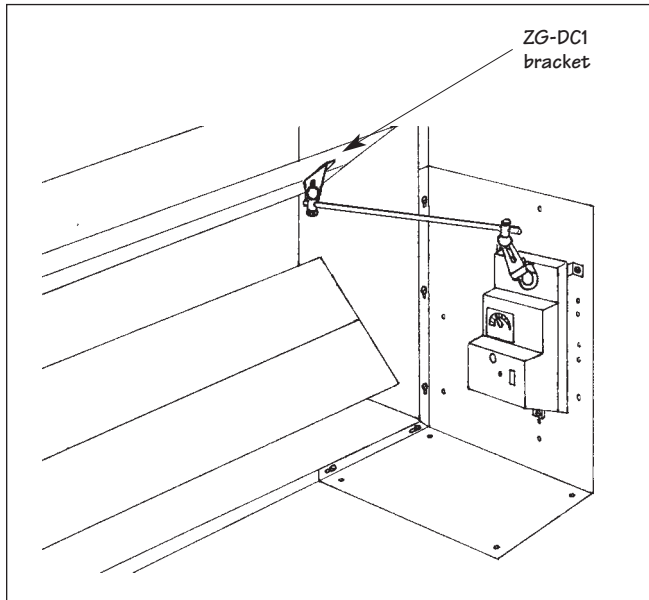

Fig. 3.2 Universal mounting bracket is attached to damper assembly.

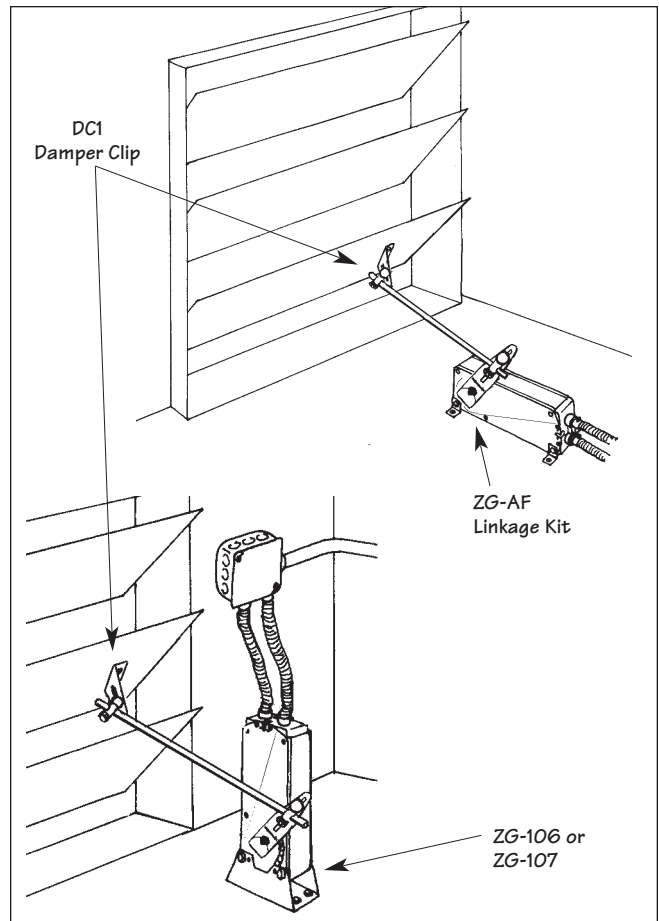

Fig. 3.3 Attached to ductwork. Operated by linkage.

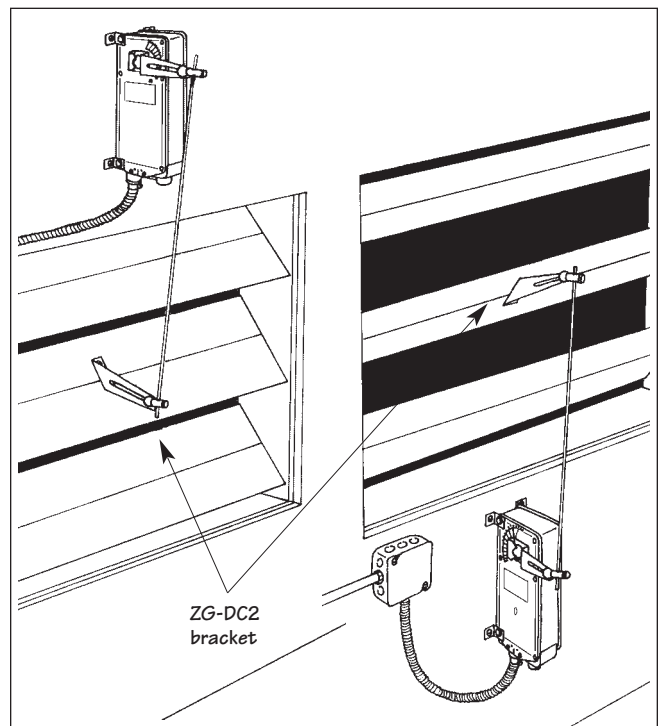

Fig. 3.4 Using the ZG-DC2 bracket with the AF...,NF... type actuators

Using universal mounting brackets with linkage

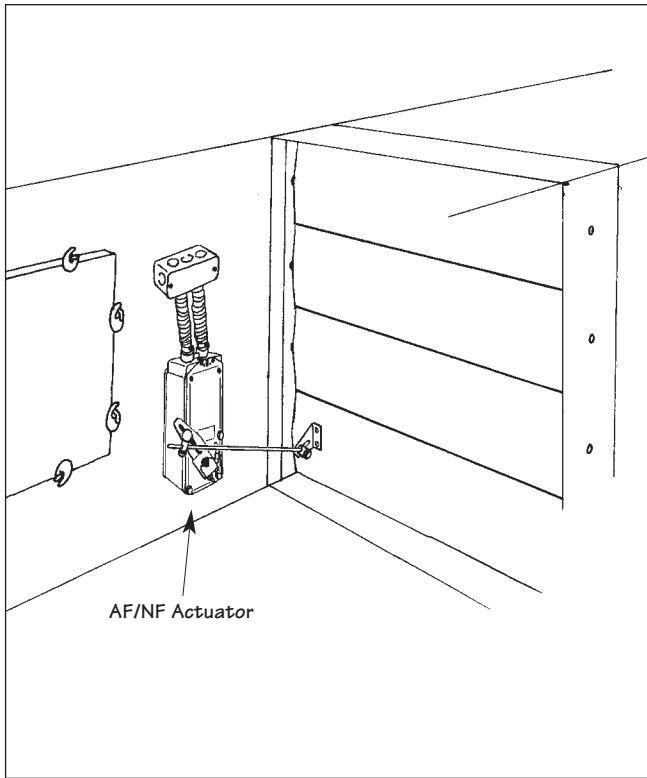

Fig. 3.5 AF or NF Series actuator mounted in the airstream using linkage using ZG-AF Crankarm Adaptor Kit

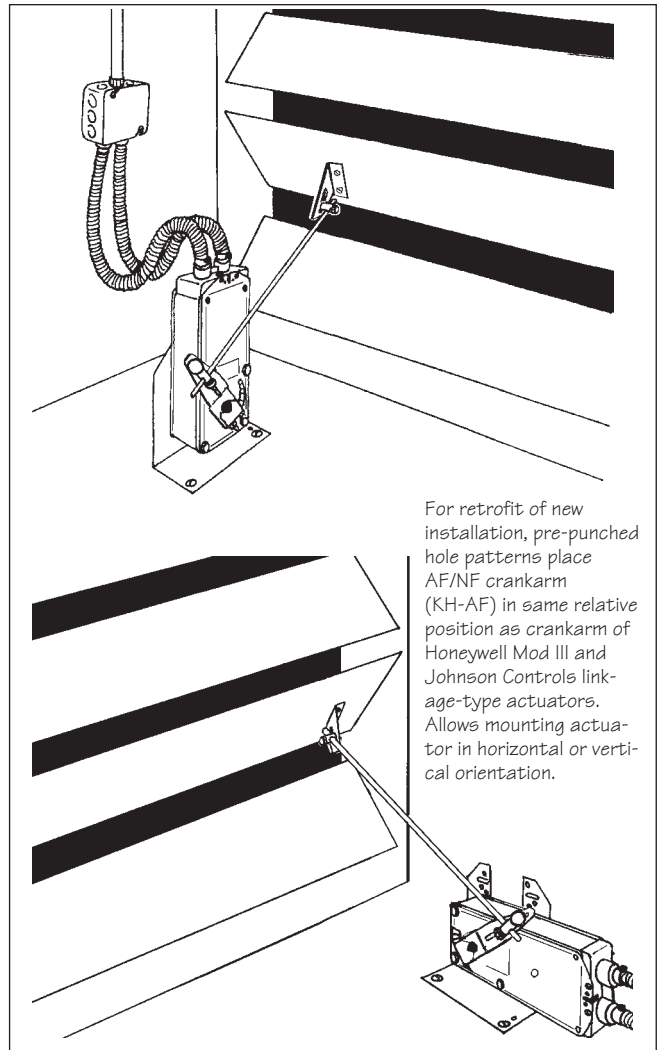

Fig. 3.7 Using the ZG-108 Universal mounting bracket with AF/NF actuators

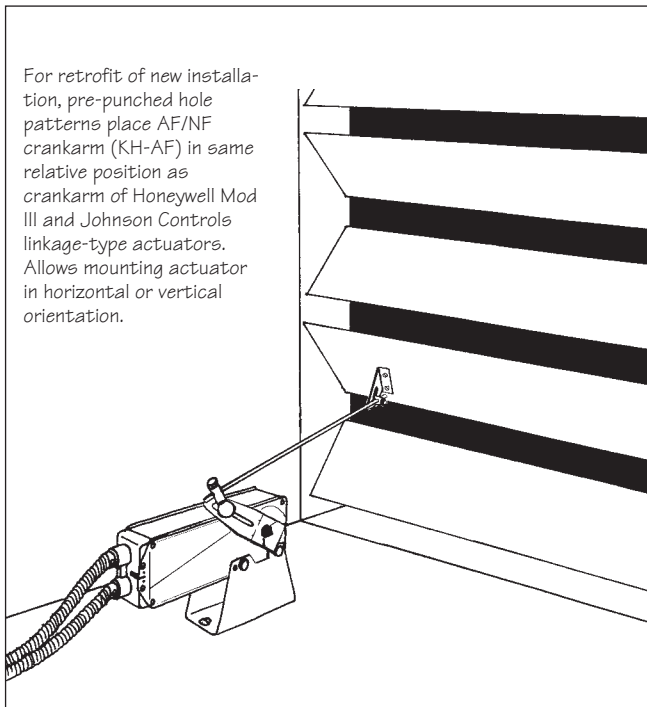

Fig. 3.6 Using the ZG-106, ZG-107 Universal mounting bracket

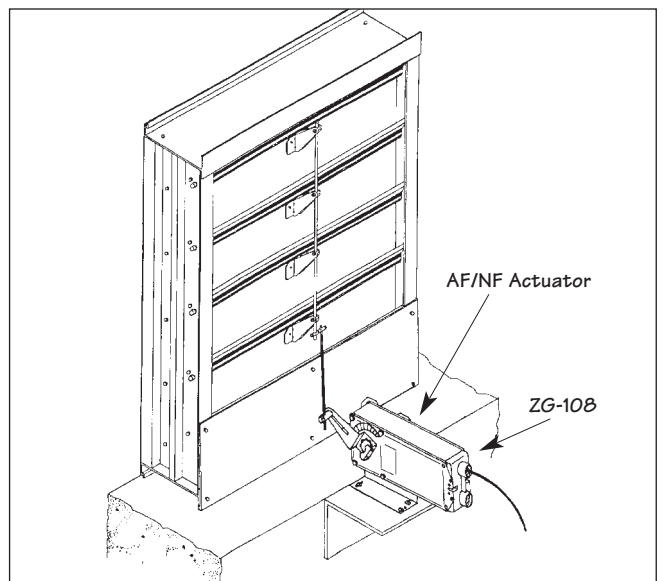

Fig. 3.8 ZG-108 Universal mounting bracket. Here it is attached to a field-fabricated 16 ga. angle iron or plate.

C20104 5 4 3 2 1 07/00-5M-IG-Subject to change. © Belimo Aircontrols (USA), Inc.

Section 3 - non-direct coupled applications

Using universal mounting brackets with linkage

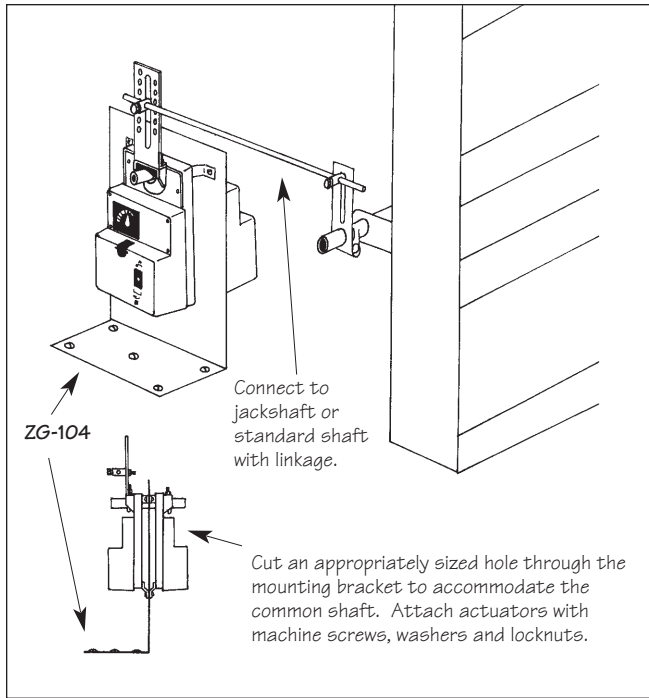

Fig. 3.9 For added torque, mount 2 actuators back-to-back on a universal mounting bracket or field-fabricated plate. Use EMT tubing as a common shaft.

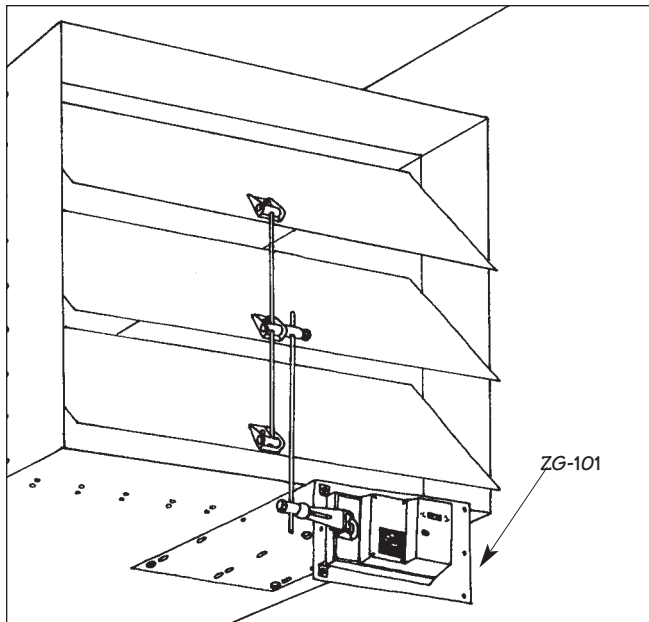

Fig. 3.10 Actuator is mounted on universal mounting bracket or field-fabricated plate

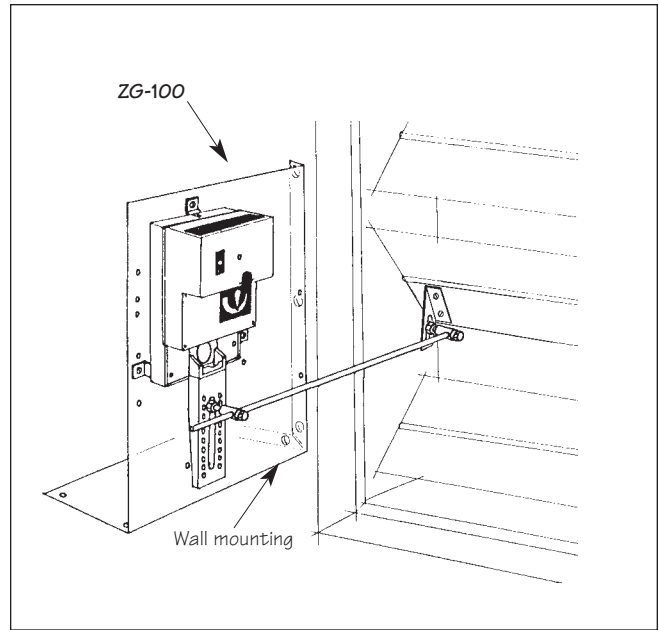

Fig. 3.11 Universal mounting bracket. Use linkage for connecting actuator to damper louvers.

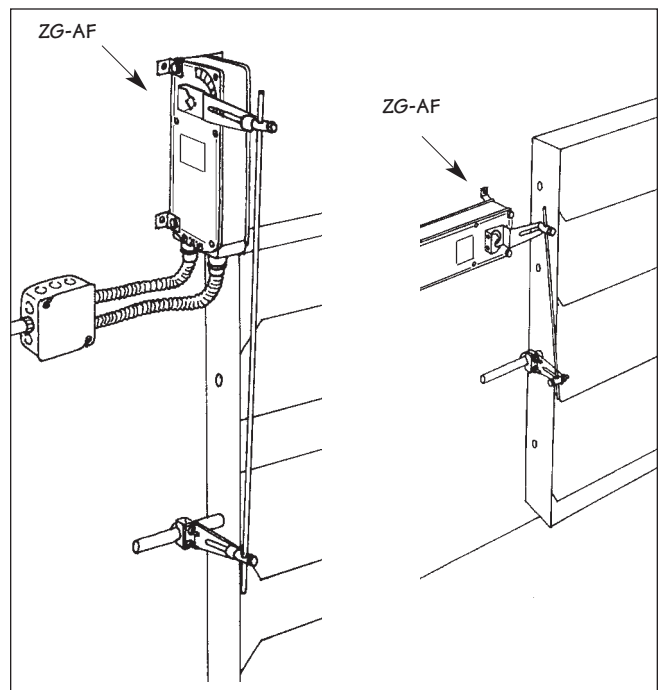

Fig. 3.12 Different ideas for attachment to walls.

Using universal mounting brackets with linkage

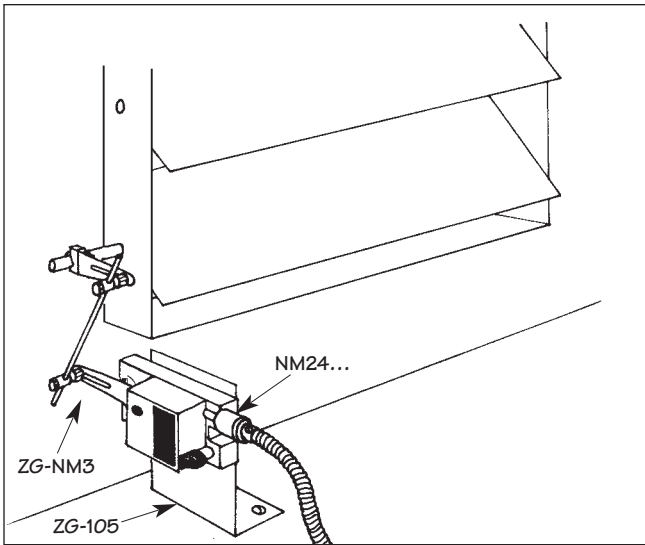

Fig. 3.13 Universal mounting bracket or a field-fabricated 16 ga. angle iron or plate. Used when there is little clearance between the damper shaft and the wall.

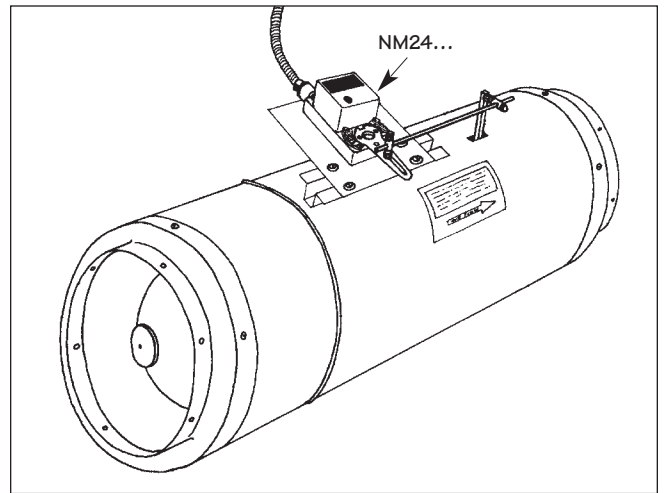

Fig. 3.15 Actuator mounted on a field-fabricated 16 ga. plate to control a cone-type VAV damper

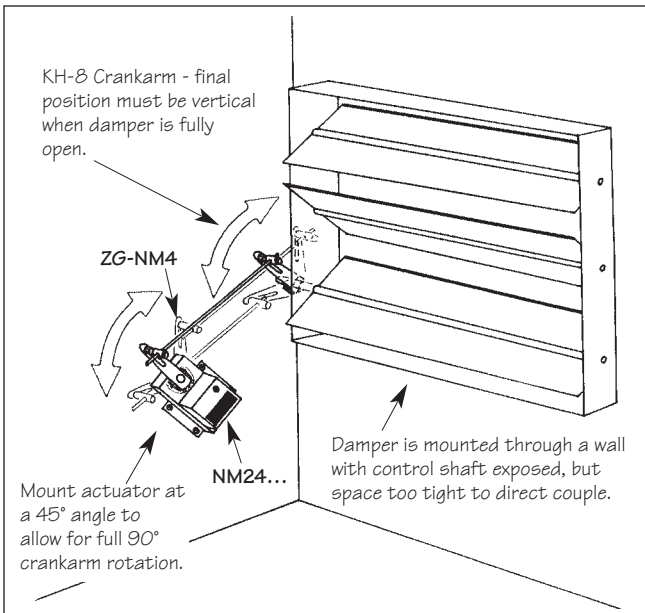

Fig. 3.14 Use this method when there is little clearance between the damper shaft and the wall.

C20104 5 4 3 2 1 07/00-5M-IG-Subject to change. © Belimo Aircontrols (USA), Inc.

Section 3 - non-direct coupled applications

non-direct mounting to jackshafts

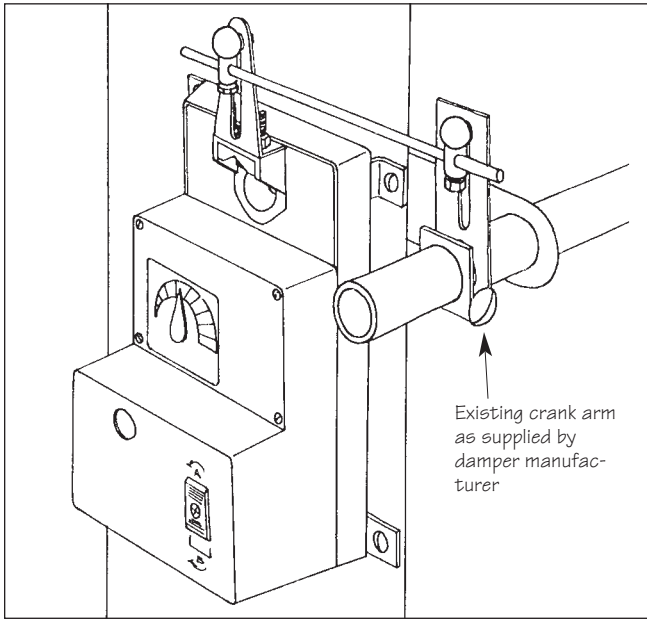

Fig. 3.16 Actuator is mounted to damper assembly. Connect to jackshaft with linkage kit.

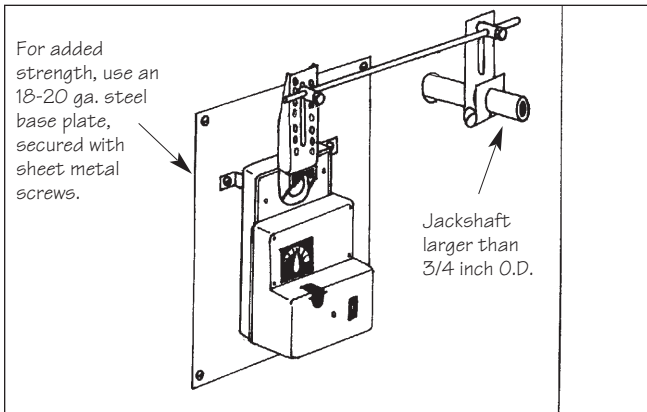

Fig. 3.17 Actuator mounted to ductwork. For larger actuators such as the GM... series, an added 18-20 ga. base plate for reinforcement is recommended. Connect actuator to jackshaft with linkage kit.

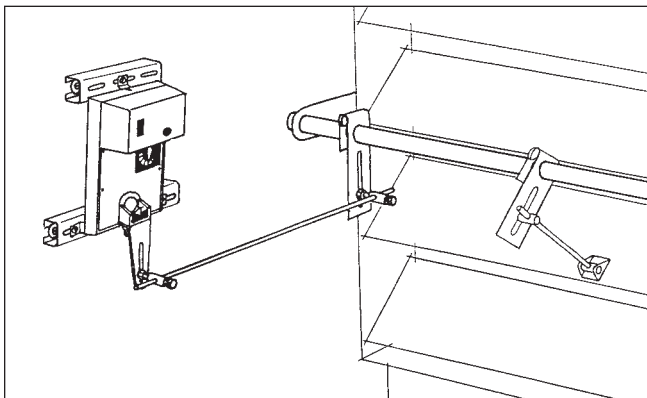

Fig. 3.18 Actuator mounted to adjacent wall. Common channel iron is used here which allows for spacing the actuator away from wall. Connect actuator to jackshaft with linkage kit.

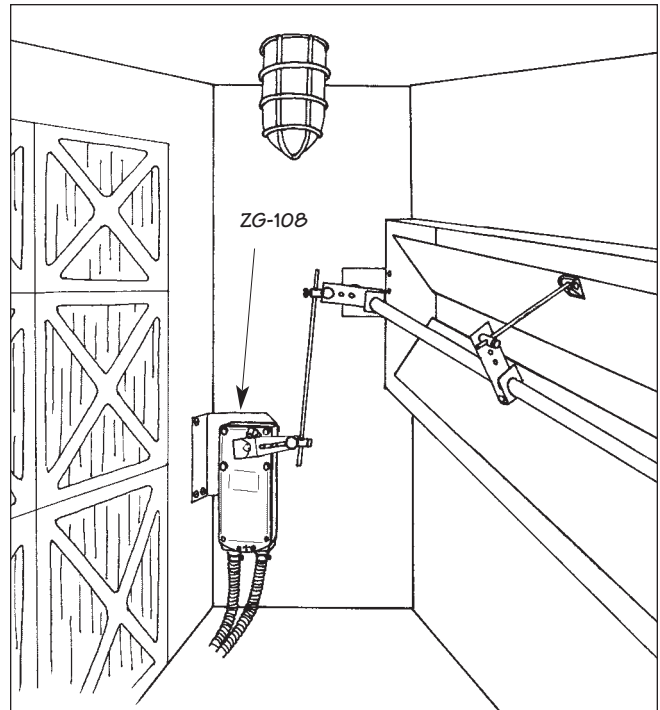

Fig. 3.19 Universal mounting bracket used to mount actuator to ductwork. Connect to jackshaft with linkage kit.

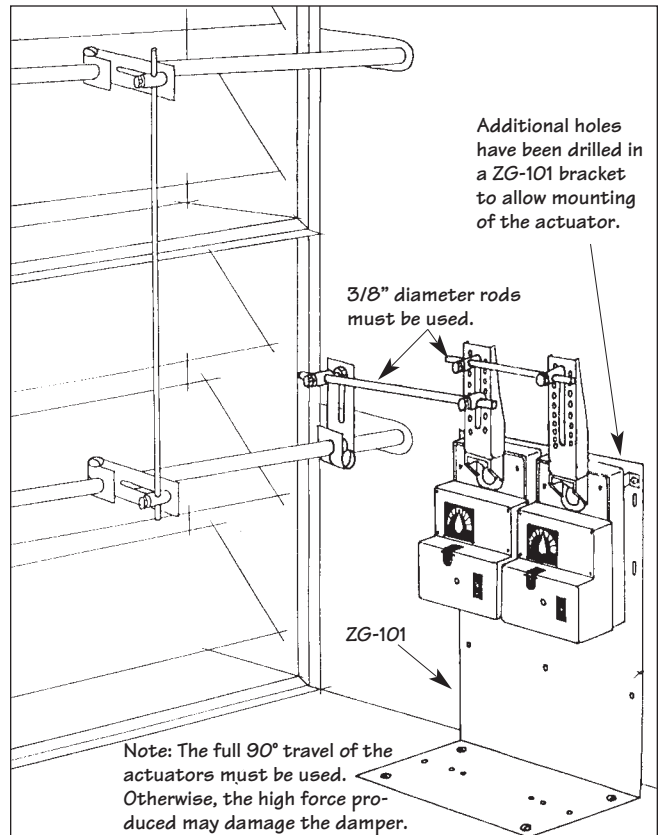

Fig. 3.20 Multiple actuator mounting. Universal mounting bracket is used to mount actuators. Connect actuators with linkage kits. This method allows you to easily meet higher torque requirements by simply increasing the number of actuators used.

mounting to inlet vanes

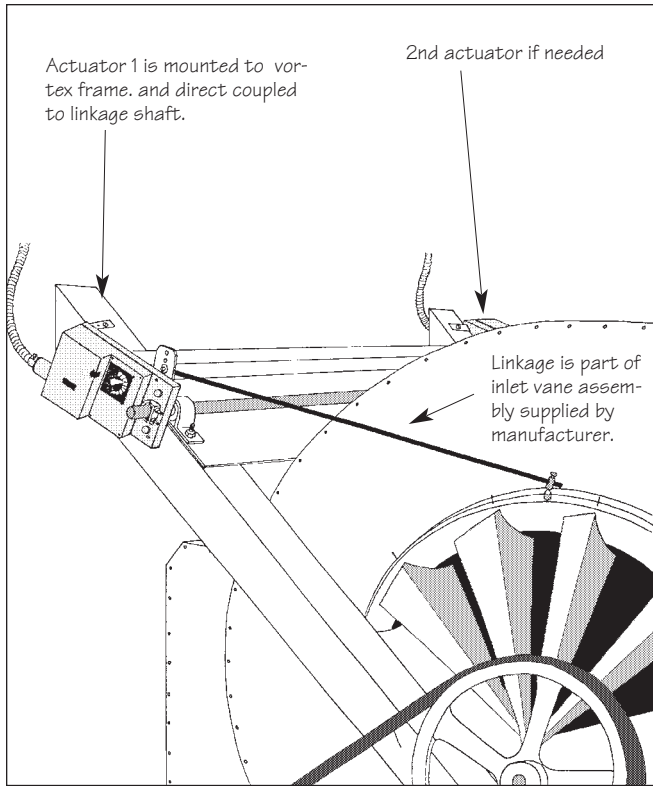

Fig. 3.21 Actuator is mounted to framework. Connect to inlet vanes with linkage. A second actuator may be mounted on the opposite side of the frame as needed.

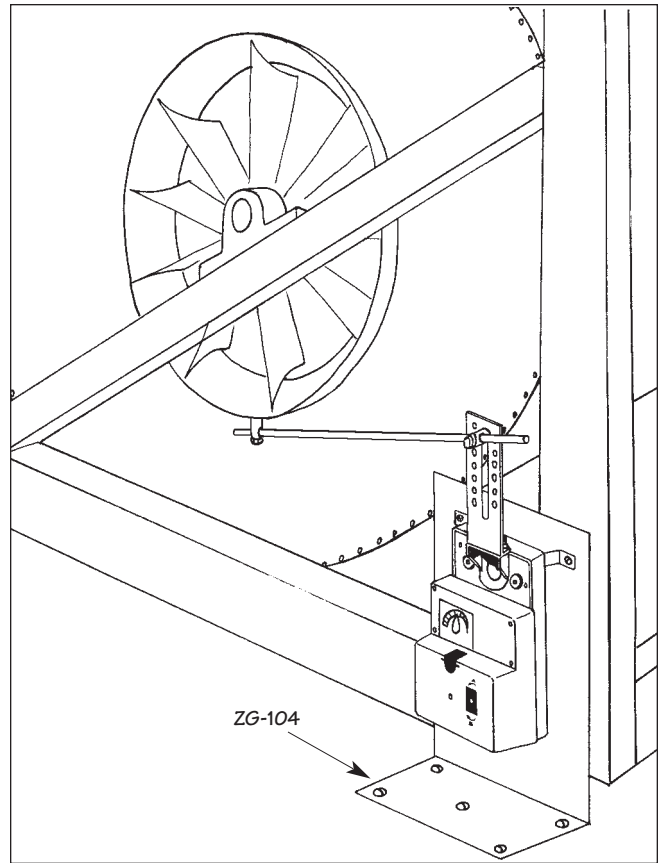

Fig. 3.23 Actuator is mounted to a universal mounting bracket or field-fabricated bracket. Connect to inlet vanes with linkage.

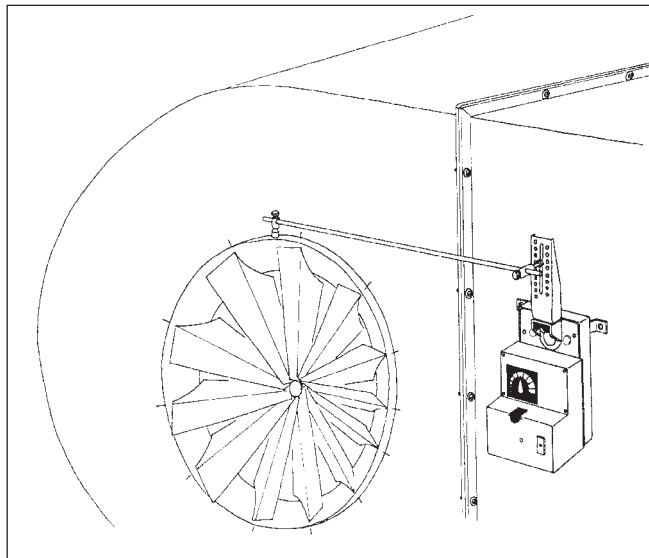

Fig. 3.22 Actuator is mounted to ductwork. Connect to inlet vanes with linkage.

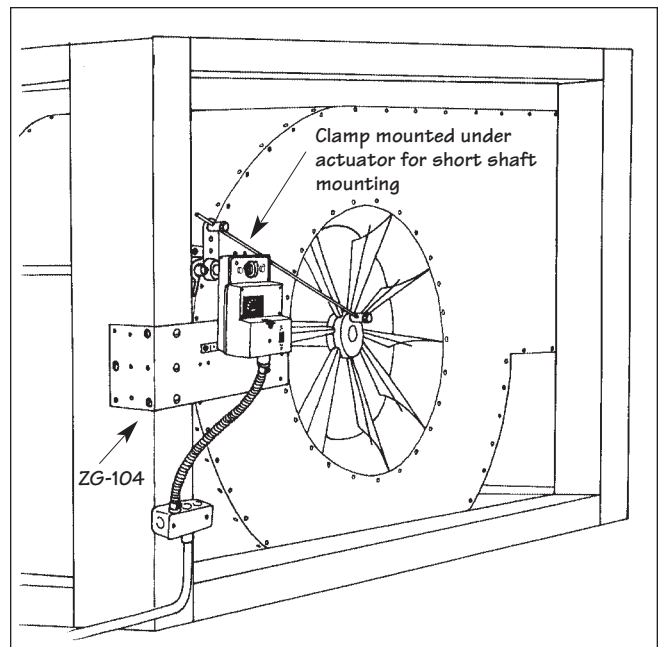

Fig. 3.24 Actuator is mounted to a universal mounting bracket or field-fabricated bracket. Connect to inlet vanes with linkage.

Replacing existing actuators

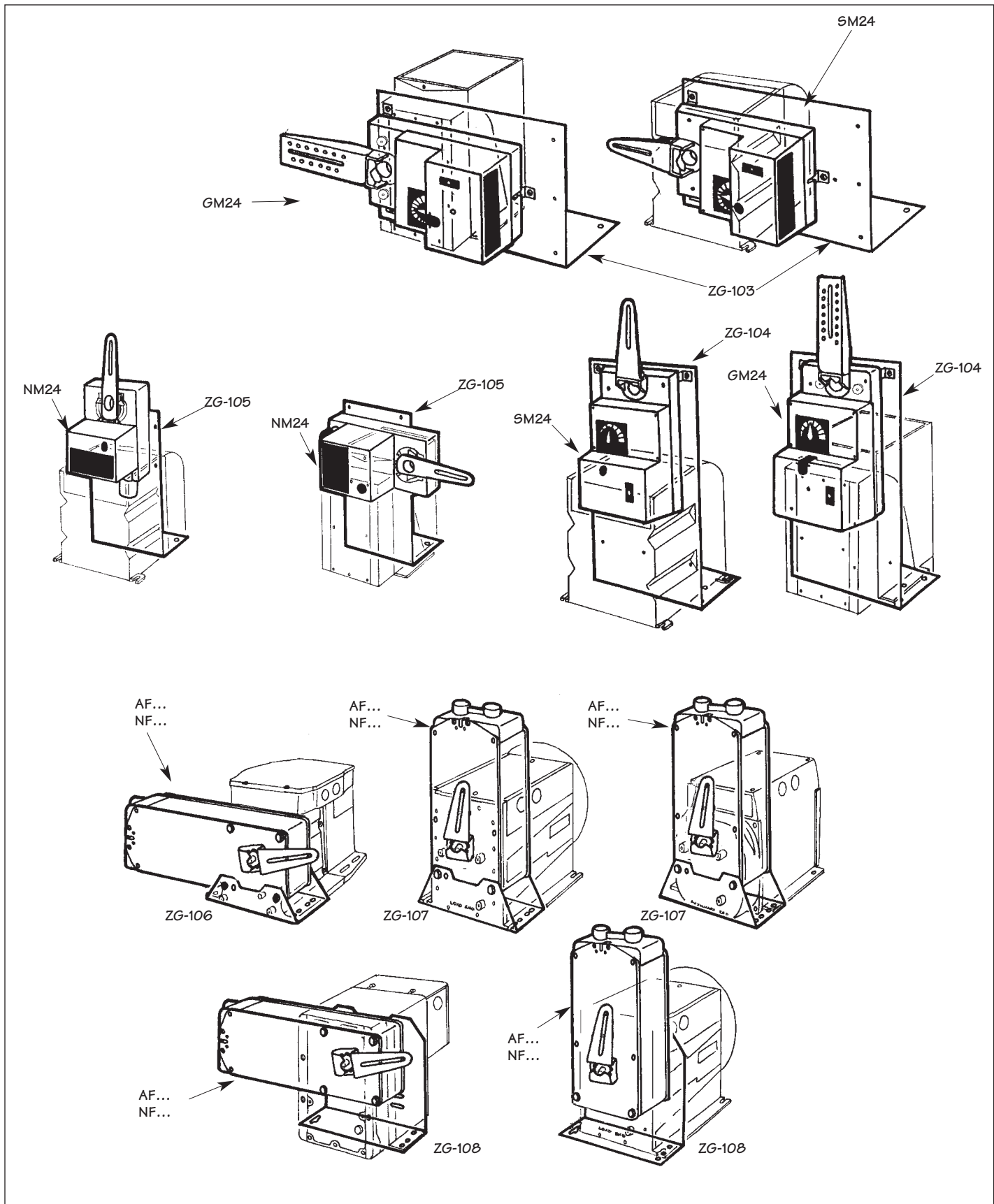

Fig. 4.1 Different methods of using the universal mounting bracket to mount Belimo actuators in place of existing, less adequate actuators.

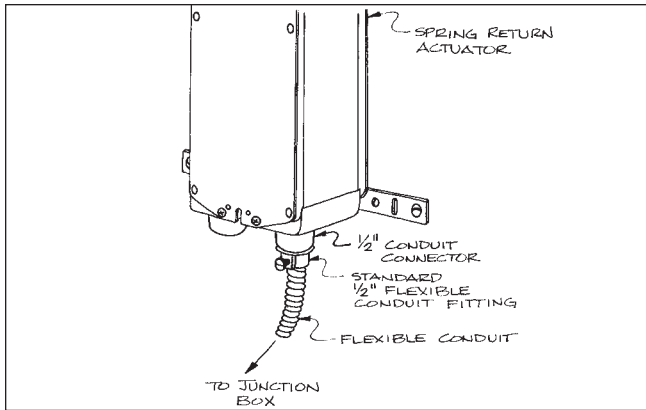

Fig. 5.1 Standard electrical configuration

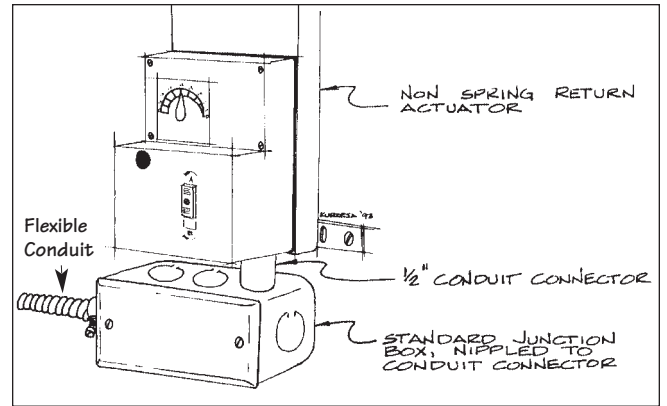

Fig. 5.3 Connecting directly to junction box

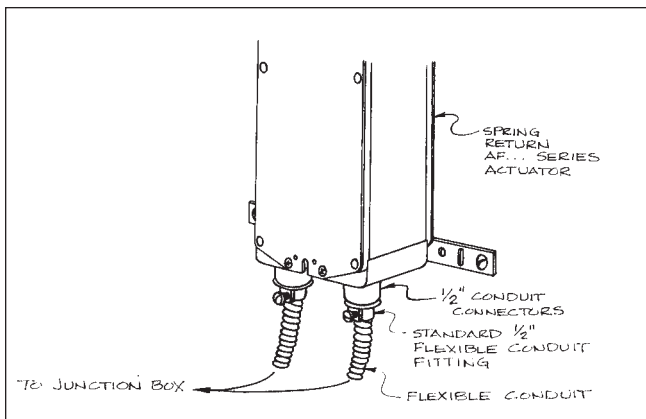

Fig. 5.2 Spring Return Actuator -standard electrical configuration

NOTE: Always use flexible conduit at the actuator.

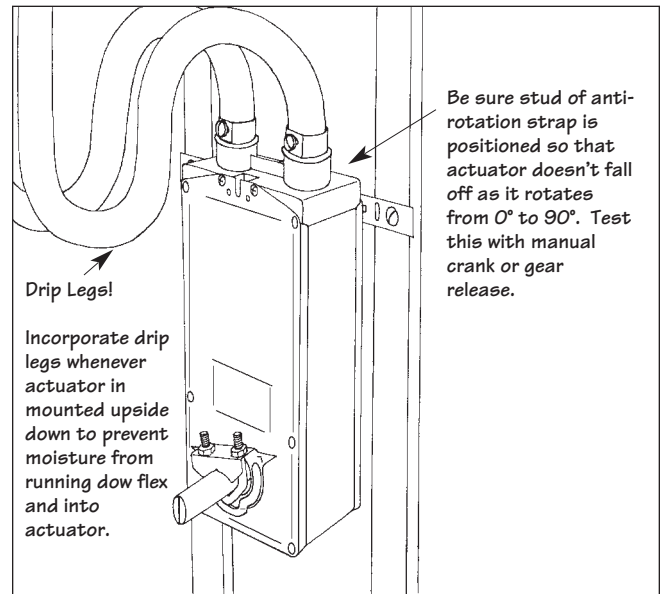

Fig. 5.4 Spring Return Actuator - connected directly to junction box

Important information

GENERAL INFORMATION

The direct coupled method of mounting an actuator to a damper should be used whenever possible. It is the most effective way to mount an actuator from a time, required space, and force transmission stand point. However, there are some applications where a linkage must be used along with, or in place of, the direct coupled method.

When using any linkage setup, it is important that the proper geometry be used. If the geometry is not correct, several problems can occur. Some of which are: a risk of binding, incorrect rotation at the damper, the full available torque may not be utilized, or excessive wear to the linkage parts or actuator.

It is possible to arrange the linkage in such a way that special functions can be provided. For example, the torque provided to the damper can be modified so that less torque is provided in the open position of a damper, but more torque would be available for tight close off. The speed of rotation can be changed. The angle of damper rotation can be limited.

General Guidelines

1. The ball joints should be placed as close to the end of the crank arm as possible. This will minimize the forces acting on the linkage parts and reduce any hysteresis in the linkage assembly. See figure 6.1.

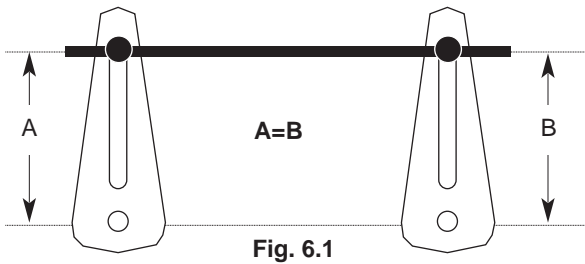

Fig. 6.1

2. The distance from the center of rotation of the crank arm to the ball joint should be the same for both crank arms. This provides uniform rotation at both crank arms. See figure 1.
3. The push rod and crank arms should be set up so the crank arms on both the actuator and damper rotate 45 degrees from a line perpendicular from the rod to the center of the crank arm rotation. This provides a balanced torque load to the damper and minimizes any chance of the linkage binding. See figure 6.2.

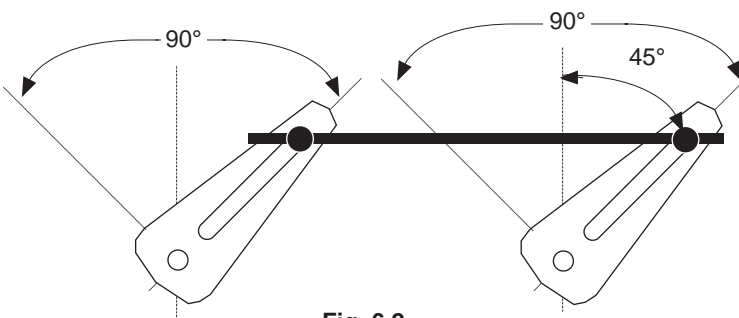

Fig. 6.2

4. Always use the full rotation of the actuator. If the damper rotation is complete and the actuator is still rotating, the linkage may bind up.
5. Always check the operation of the linkage assembly to make sure it operates the damper properly between the fully open and fully closed damper position.

Technical Information

The definition of torque is that it is a turning force. When talking about torque from an engineering standpoint we talk about a force (F), acting on the length of an arm (L), producing a turning force (T) given in a unit which incorporates both a unit of length and force in its description. Looking at this as an equation we would have:

$$T = L \times F ; \text{ where in common applications } L \text{ would be in inches, } F \text{ would be in pounds, and } T \text{ would be shown as inch-pounds or pound-inches}$$

Figure 6.3 shows a crank arm with a length between the pivot point to the ball joint attachment of 4 inches. At the ball joint it shows we are applying a force of 25 pounds. The resulting torque would be 100 in-lb.

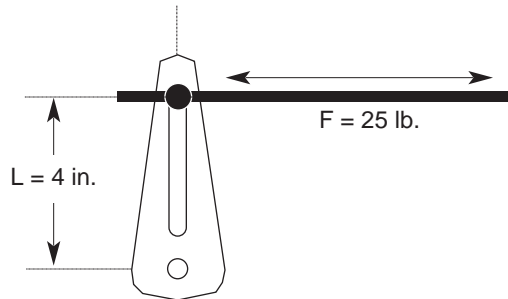

Fig. 6.3

$$T = L \times F = 4 \text{ in} \times 25 \text{ lb} = 100 \text{ in-lb}$$

When using this equation with actuators it is more common to see it in the following forms:

$$F = T / L \quad \text{or} \quad L = T / F$$

The rating of most electronic actuators is given in torque and it is usually required to find either the force from the crank arm or the length of the crank arm for the application. In figure 6.3, if we said the actuator had a torque of 100 in-lb, and needed a force of 25 lb, we would need a 4 inch crank arm.

$$L = T / F = 100 \text{ in-lb} / 25 \text{ lb} = 4 \text{ in}$$

Unfortunately, the equation $T = L \times F$ is only correct when the force acts upon the crank arm at a 90° angle. At any angle other than 90° the resultant torque or force is dependent on the crank arm effective radius. The effective radius (R), shown in figure 6.4, is the distance between the point on the push rod which is perpendicular to the center of rotation of the crank arm and the center of rotation.

Important information

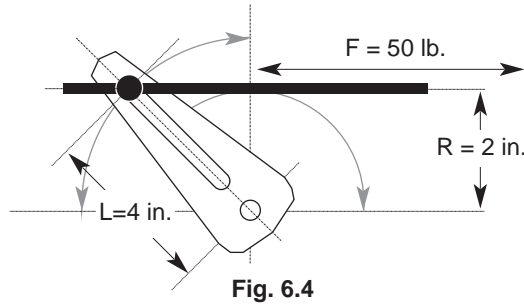

We now have to substitute the effective radius (R) in place of the crank arm length (L) in the torque equation.

$$T = R \times F \text{ or } F = T / R$$

Note: R has its greatest value at the point where the crank arm is perpendicular to the push rod. At this point R equals L.

Figure 6.4 shows the same torque and crank arm as figure 6.3; however, the crank arm is now not perpendicular to the push rod. At this point in the crank arm rotation we show an R of 2 inches. With the output torque of 100 in-lb, the resulting force at this point is 50 lb.

$$F = T / R = 100 \text{ in-lb} / 2 \text{ in.} = 50 \text{ lb}$$

As the effective radius (R) changes during the crank arm rotation, the relationship between torque, force, and even rotational speed changes. By analyzing the crank arm orientation between the actuator and damper, special set ups can be made to optimize certain damper applications.

SPECIAL APPLICATIONS

High Close Off Torque

Low leakage dampers with blade seals require a greater close-off torque than the normal operating torque. By setting up the linkage correctly, the torque provided to the damper at close-off can be multiplied.

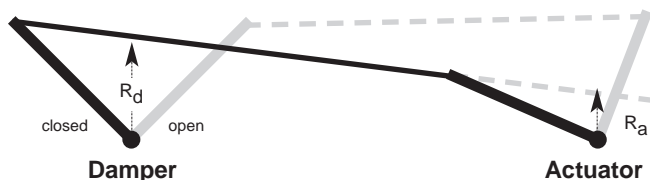

Fig. 6.5

Figure 6.5 shows a linkage arrangement where, when the damper is in the closed position, the angle between the actuator crank arm and push rod is relatively large. This angle makes the resulting effective radius at the actuator (Ra) small; this in turn causes a higher force to act on the push rod. When the damper is at close-off, the damper crank arm is adjusted so it is at an angle creating a relatively large effective radius (Rd) at the damper. The large force from the push rod is multiplied by the effective radius (Rd) at the damper and the result is a higher torque at the close off position. The torque from

the actuator is actually multiplied at this point by a factor M which is equal to Rd/Ra.

$$M = R_d / R_a$$

One important thing to remember is that at the opposite end of rotation the torque can be reduced to a point where minor binding or friction could lock up the damper.

Faster Response Time At Damper

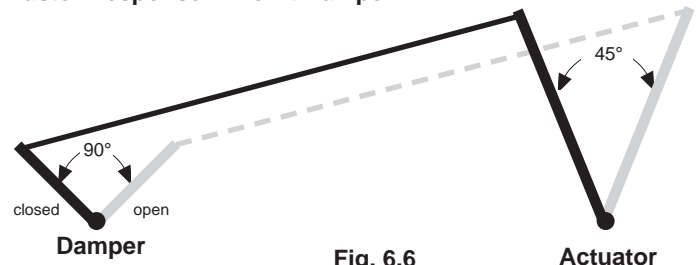

Fig. 6.6

Figure 6.6 shows an application where the actuator crank arm is approximately twice as long as the damper crank arm. This results in a rotation at the damper shaft of 90° with only 45° of rotation at the actuator. Using only 45° of the actuator's rotation gives the advantage of the damper operating at twice the actuator's normal speed. A draw back is that the actuator torque is cut in half. It is recommended that the actuator be limited to only 45° of rotation either mechanically (preferred) or electrically. If this is not done, it is possible that the linkage or the damper may be damaged as the actuator continues to rotate.

Limiting Damper Rotation

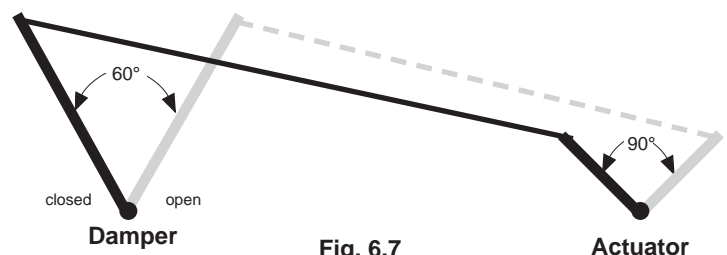

Fig. 6.7

Fig 6.7 shows an application where we are limiting the degree of rotation while still using the full 90° rotation of the actuator. The crank arm shown of the actuator is shorter than the arm on the damper. Because of the smaller arc produced at the actuator arm, the push rod travel cannot rotate the damper arm through a full 90° rotation.

General Comments

The use of a linkage assembly can be advantageous if a solution to a special need is required. However, great care must be taken in planning the linkage geometry. Any change made to the linkage has an effect on more than one condition. As an example, if you adjust the linkage for more torque, you will at the same time effect the damper rotational speed and the angle of the damper rotation. In any special application it is necessary to use a trial-and-error, back-and-forth method to set the required parameters. This can be a very time consuming process, but it should be done.

Section 6 - Damper linkages

Applications using linkages

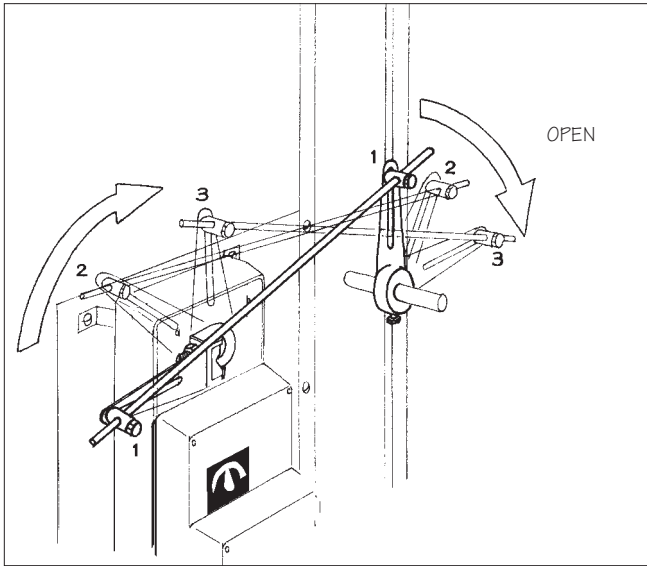

Fig. 6.8 Back-to-Back: The Easiest Method of Increasing Break-away Torque

(1) is the start point; (3) is the end point. Damper movement is slowest from positions (1) to (2) and increases in speed to position (3). For example: If a 90 in-lb actuator is used, torque at position (1) is approximately 180 in-lb while torque at position (3) is approximately 45 in-lb. Thus, greatest torque is supplied where it is needed most - at the beginning of the damper's movement to assure break-away from the side seals.

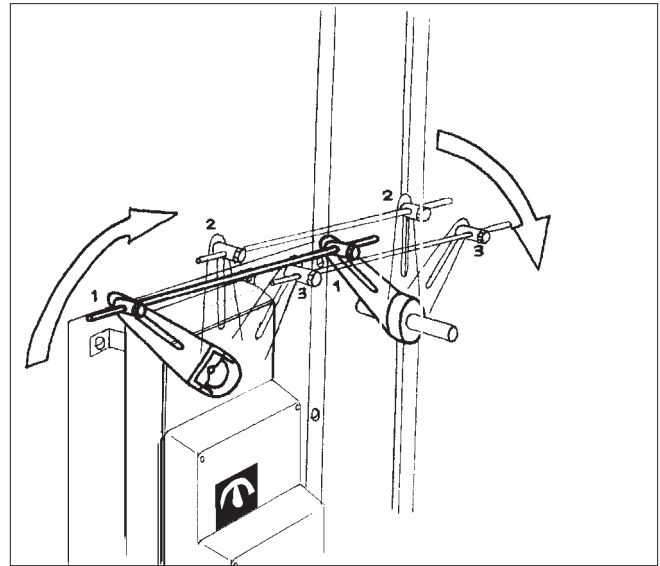

Fig. 6.9 Typical Parallel Crankarm Operation

Here, both crankarms remain parallel throughout the complete arc of movement, ensuring consistent torque at all times. This is one of the most common methods of mounting using linkage.

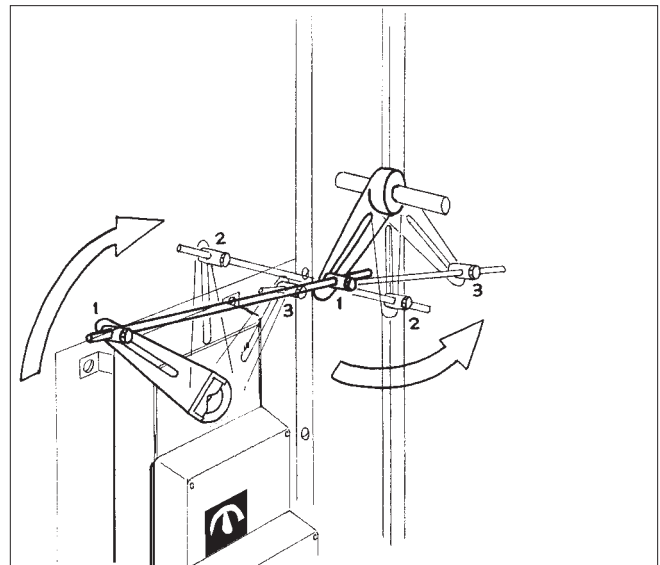

Fig. 6.10 Over-and-Under

Here, the crankarms are set in opposite directions. This method is used in situations where space is limited.

A large grid of 20 columns and 30 rows for taking notes or working. The grid is composed of thin gray lines forming a series of small squares. The grid is empty and occupies most of the page.



Print Documentation

Overview

- Company Profile
- Product Guide and Price List

Product Documentation

- Spring Return Actuators
 - AF Series, 133 in-lb
 - NF Series, 60 in-lb
 - LF Series, 35 in-lb
- Non-Spring Return Actuators
 - GM Series, 266 in-lb
 - AM Series, 160 in-lb
 - NM Series, 70 in-lb
 - LM Series, 35 in-lb
- Control Valves
 - Characterized Control™ Valves
 - NV Series Actuator, Globe Valves (1/2"-2")
 - Flanged Globe Valves (2 1/2"-6")
 - Zone Valves
 - Butterfly Valves
- Multi-Function Technology®
- Accessories
 - Electronic
 - Mechanical

Reference

- Mounting
- Wiring
- Damper Applications
- Valve Applications
- Sizing and Selections
- Submittals

News

- *Belimo Direct* Product Newsletter
- *Belimo Feedback* Application Newsletter

Electronic Documentation

Complete product catalog and selection tools for damper actuators and control valves at www.belimo.com, or on CD-ROM.

Serving HVAC Professionals Throughout the Americas

Belimo Aircontrols (USA), Inc.
Corporate Headquarters/Manufacturing
Distribution/Customer Service Center
Latin American Customer Service
43 Old Ridgebury Road, P.O. Box 2928
Danbury, CT 06813
(800) 543-9038 • (203) 791-9915
Fax (203) 791-9919
Toll free fax order line:
1-800-ACTUATE (1-800-228-8283)

Belimo Aircontrols (USA), Inc.
Distribution/Customer Service Center
1675 East Prater Way, Suite 101
Sparks, NV 89434
(800) 987-9042
(775) 857-4243
Fax (775) 857-4255
Toll free fax order line:
1-800-987-8875

Belimo Aircontrols (CAN), Inc.
Corporate Headquarters
Distribution/Customer Service Center
14/15 - 5716 Coopers Avenue
Mississauga, Ontario L4Z 2E8
(905) 712-3118
Fax (905) 712-3124

Belimo Servomoteur, Inc.
Corporate Headquarters
Customer Service Center
2790 Chemin Du Lac
Longueuil, Québec J4N 1B8
(450) 928-1440
Fax (450) 928-0050